



EARLY MODEL FEED MIXER PARTS & MAINTENANCE MANUAL

MODELS MANUFACTURED FROM 1955 TO 1985
300, 350, 400, 302, 354, 406, 458, F, R, M, MS & T

This manual consists of a broad range of mixers because many of these older units have weathered off any decals or markings that verify their exact model. The below suggestions will help determine which model.

1. Models 300, 350, 400 preceded the later models 302, 354, 406 and 458
2. The lengths of the mixer (inside dimensions) can be 12 feet, 14 feet, 16 feet or 18 feet.
3. Is it a truck mount or trailer type?
4. Is the primary drive located in the front or the rear?
5. The earliest models were built with a single auger discharge with round spout or flat bottom spout.
6. Later models utilized several variations of the dual auger discharge. To determine which style discharge look for these variables.
 - Gearbox location; 1) under mixer on passenger side. 2) driver side, left of the discharge. 3) two gearboxes attached directly to each auger
 - Length of discharge, measure from back plate to end of auger

INSTALLATION INSTRUCTIONS

1. The Models 300M and 350M Harsh Mobile Mix® feed boxes require the following PTOs:

Gear Box	P.T.O. Rotation	P.T.O. % Engine RPM
58055	engine	50 to 60
8309	opposite	85 to 90
BJ48	engine	50 to 60

2. The gear box input speed should be 1750 RPM minimum. This RPM gives the gear box an adequate horsepower rating.

MAINTENANCE TIPS

1. For longer chain life:

- Keep the sprockets aligned;
- Keep the chain drive assembly free of dirt and other foreign matter;
- Maintain proper chain tension — New chains elongate slightly when used, therefore, it is essential to check chain tension and adjust idlers often when a mixer is new, or a chain has been replaced;
- Keep chain lightly lubricated -- use one of the following lubricants:

Operating Temperature	Recommended Non-Detergent Oil
-5° to 20°F	SAE 10
20° to 50°F	SAE 20
50° to 110°F	SAE 30
Dusty Conditions	Dry Lube

- Keep set screws in sprocket drives tight.
- Replace all worn components.
- Grease U-joints, drive shaft, and discharge drive every 40 hours.
- Keep drive shaft spline-free and lubricated.
- Keep stabilizer rod ends well oiled. (Mixer with Scales only).
- To increase the bearing life:
 - Install grease zerk fittings on the bearings and grease every four weeks or every 400 hours, whichever comes first. Use one of the following greases or the equivalent:

ALVANIA No. 2
 TEXACO MULTIFAK No. 2
 HUMBLE LIDOK No. 2
 SINCLAIR LITHOLINE Multi-Purpose
 SUN PRESTIGE No. 41

8. Gear Box Maintenance:

- Drain all gear boxes at least once per year. Flush and reservice with the following oil:
 - Discharge Gear Box
20 Wt. Non-Detergent Oil (Max. 1 Qt.)
 - Main Drive Gear Box
 - Gear Box 8309 & 58055
20 Wt. Non-Detergent Oil
 - Gear Box BJ48
90 Wt. Non-Detergent Oil

9. Hydraulic Oil (Mixers w/Hydraulic Controls only)

- The following oils (or equivalent) are recommended and were selected on their ability to raise the hydraulic cylinders in a minimum of time in addition to anti-corrosion, anti-wear, and anti-foaming properties.
 - The best all-weather oils are:
 - Texaco -- Aircraft BB
 - Shell -- Aeroshell Fluid 4
 - Exxon -- Univis J43
 - The following oils or their equivalent are acceptable at temperatures above freezing:
 - Texaco
 - Rando A
 - Texamatic Dexron
 - Texamatic F
 - Co-op
 - Automatic Trans. Oil Dexron
 - Automatic Transmission Oil F
 - If, in an emergency, any of the oils in item 2 becomes too thick in cold weather, thin the oils with up to 20% #1 Diesel fuel, however, the oil should then be replaced before the hot summer days.
- Change oil when it becomes dirty. Dirty oil will cause increased seal wear and eventual oil leakage.

SAFETY INSTRUCTIONS

- Keep all shields in place while operating the Mixer.
- Stop Mixer before making adjustment.
- Keep hands, feet, and clothing from moving parts.
- Stay off Mixer while in operation.

HARSH

MOBILE MIX

MAIN DRIVE SYSTEMS FOR

**302T - 354T, 406T, 302M - 354M, 354MS - 406M, 458M
FRONT AND REAR**

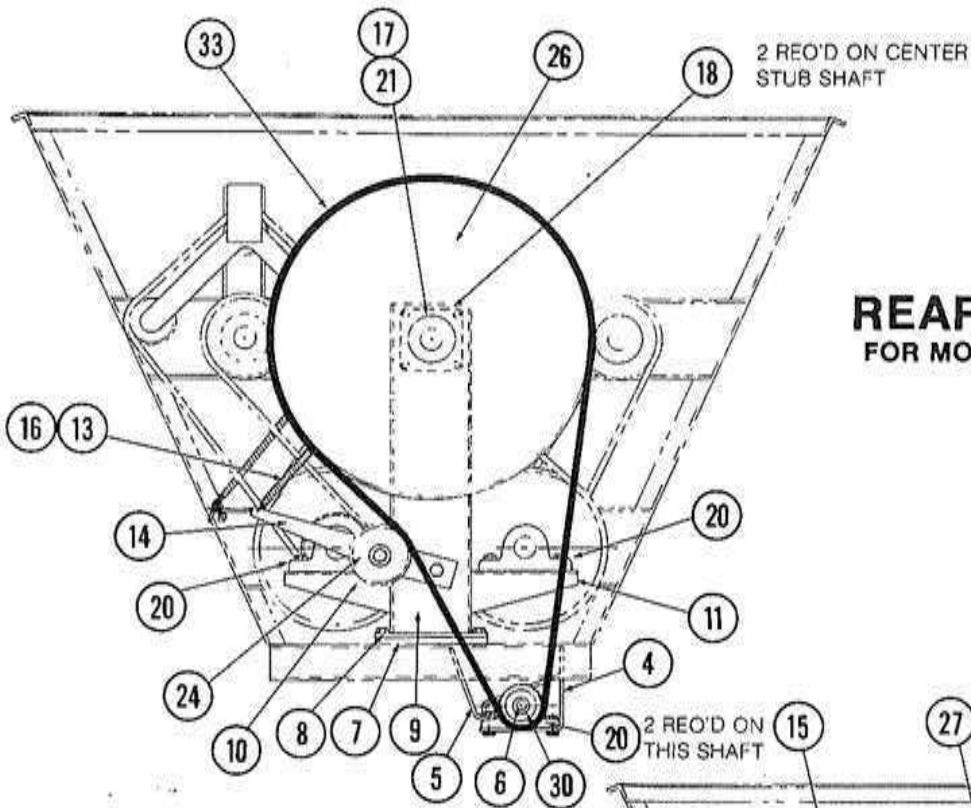

REAR DRIVE SYSTEM FOR MODELS 302T & 354T (540 RPM)

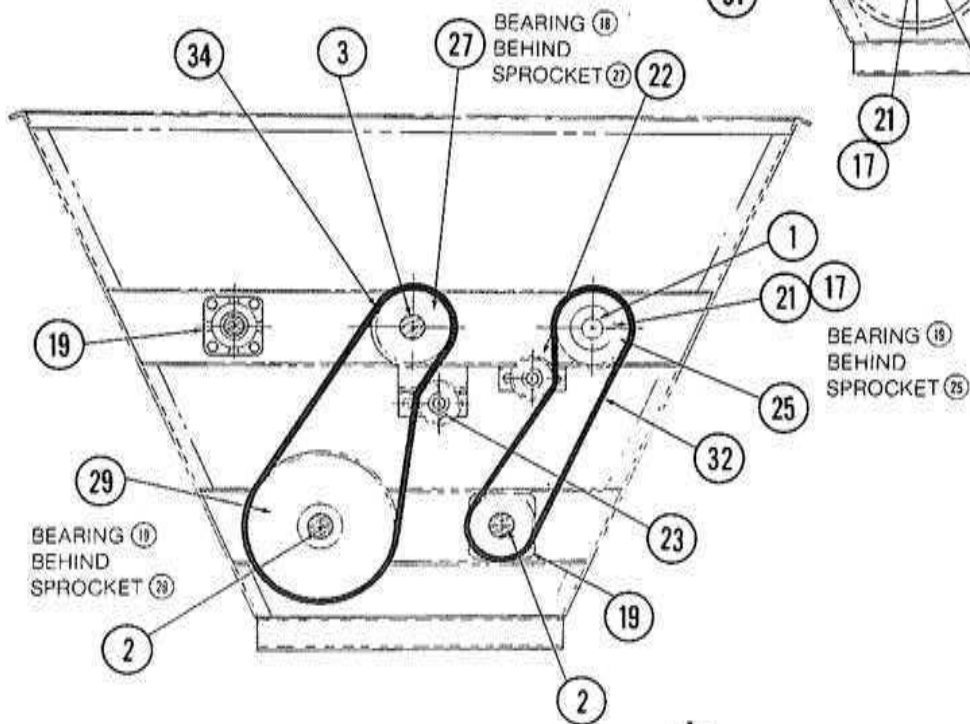
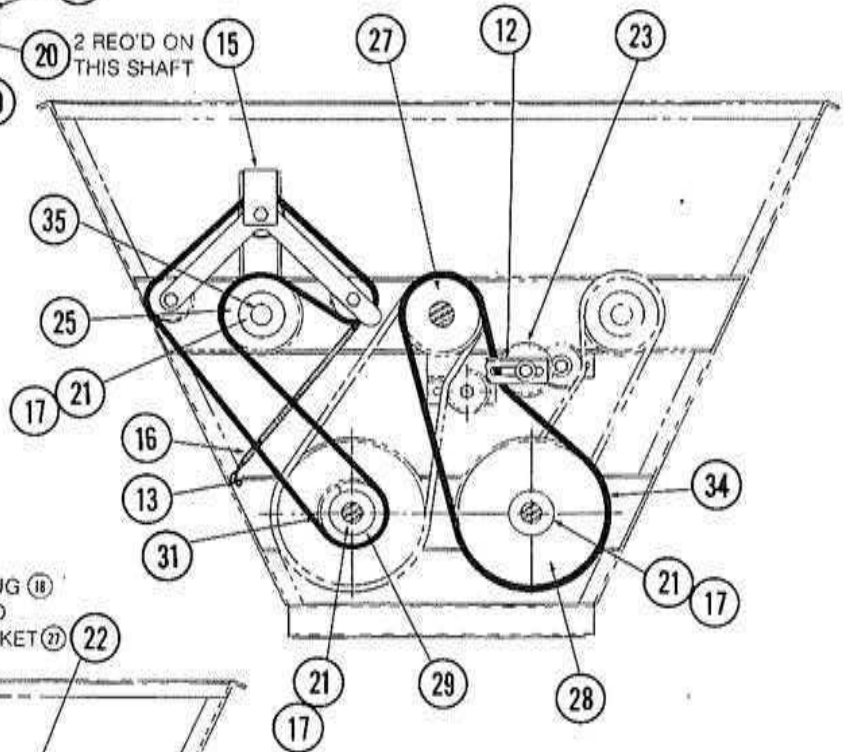

REAR DRIVE SYSTEM
MODELS 302T & 354T (540 RPM)

ITEM	PART #	DESCRIPTION	QTY.
1	A10653	Flanged Shaft 2 7/16 x 9 3/4 Lg.	2
*2	A13531	Flanged Shaft 2 7/16 x 16 7/8 Lg.	2
*2	A14731	Flanged Shaft 2 15/16 x 12 Lg. w/o pillow block bearing	2
*3	13532	Stub Shaft 2 7/16 x 19 Lg.	1
*3	12678	Stub Shaft 2 15/16 x 20 Lg.	1
4	13609	Bearing Bracket	1
5	13610	Bearing Bracket Brace	2
6	13608	Shaft, Rear (2" Dia)	1
7	13299	Bottom Support Channel Plate	1
8	13381	Top Support Channel	1
9	13298	Support Channel	1
10	13314	Bearing Support Angle (left)	1
11	13387	Bearing Support Angle (right)	1
12	A12499	Idler Sprocket Mount Ass'y	1
13	10820	Tightener, Chain	2
14	A10209	Chain Tightener Ass'y	1
15	A12713	Auger Reversing Ass'y	1
16	100447	Spring, 1 1/4 x 11 3/4	2
17	10984	Key, Square, 5/8 x 3	5
*18	100051	Bearing (FB900 x 2 7/16)	2
*18	101410	Bearing (RPB 2 15/16) w/o pillow block bearing	2
*19	100048	Bearing, Flanged (2 7/16)	4
*19	101707	Bearing, Flanged (2 15/16) w/o pillow block bearing	4
20	100050	Bearing, Pillow Block (2")	4
21	100078	Bushing (R1 x 2 7/16)	7
*21	100066	Bushing (R1 x 2 15/16) w/o pillow block bearing	*2
22	A13374	Idler Sprocket (HB80 A12 x 1")	*1
23	A13375	Idler Sprocket (HB100 A12 x 1")	2
24	A13376	Idler Sprocket (HB80 A18 x 1")	1
25	100073	Sprocket (H80 R40)	2
26	A15140	Sprocket (H80 R112)	1
27	100076	Sprocket (HDS 100 R17)	1
28	100074	Sprocket (HDS 100 R48 / 80 R24 (R.H.))	1
29	100742	Sprocket (HDS 100 R48 / 80 R24 (L.H.))	1
30	100069	Sprocket (H80 B14 x 2")	1
31	101991	Roller Chain (#80 x 136 Pitch)	1
32	10619	Roller Chain (#80 x 84 Pitch)	1
33	11383	Roller Chain (#80 x 158 Pitch)	1
34	10620	Roller Chain (#100 x 93.75 Pitch)	2

REAR DRIVE SYSTEM

MODELS 302M, 354M, 302T & 354T

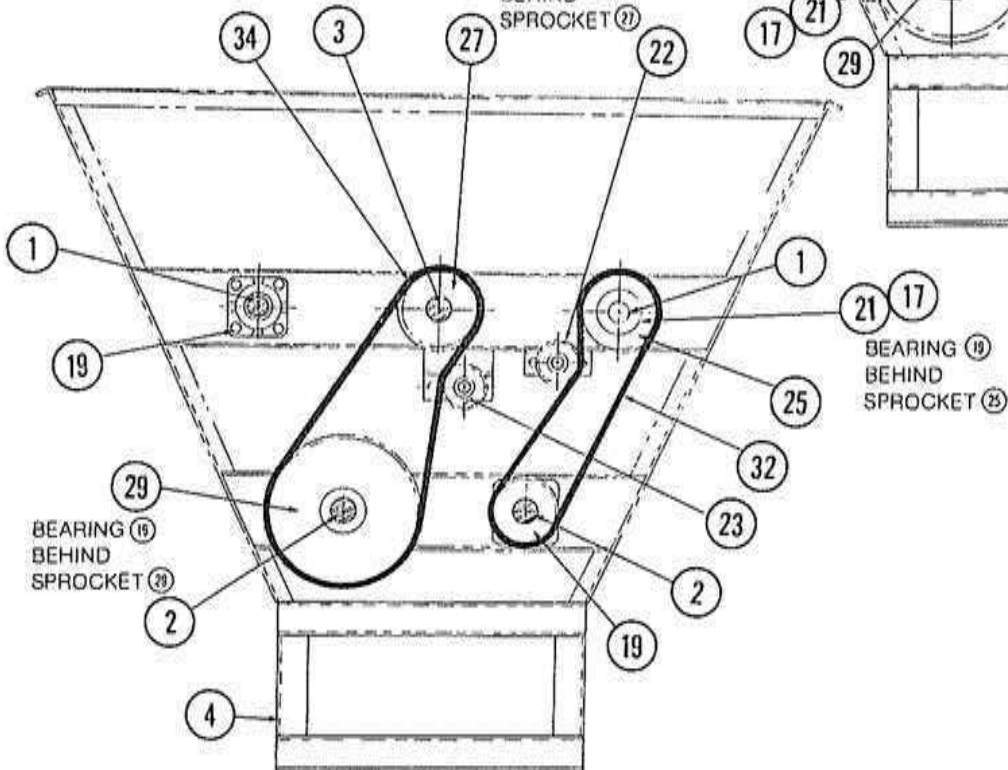
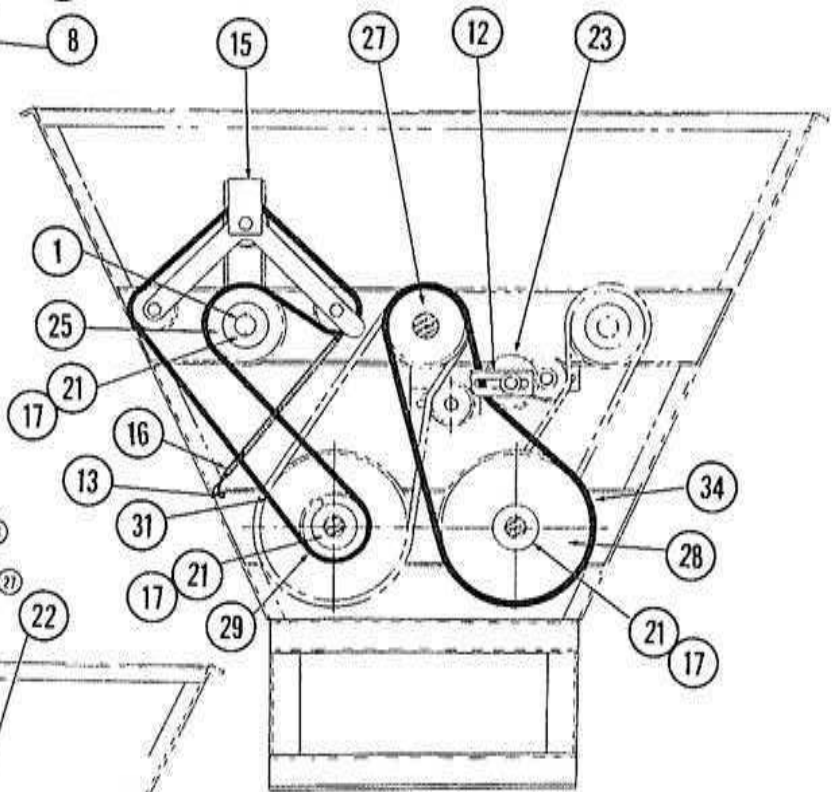
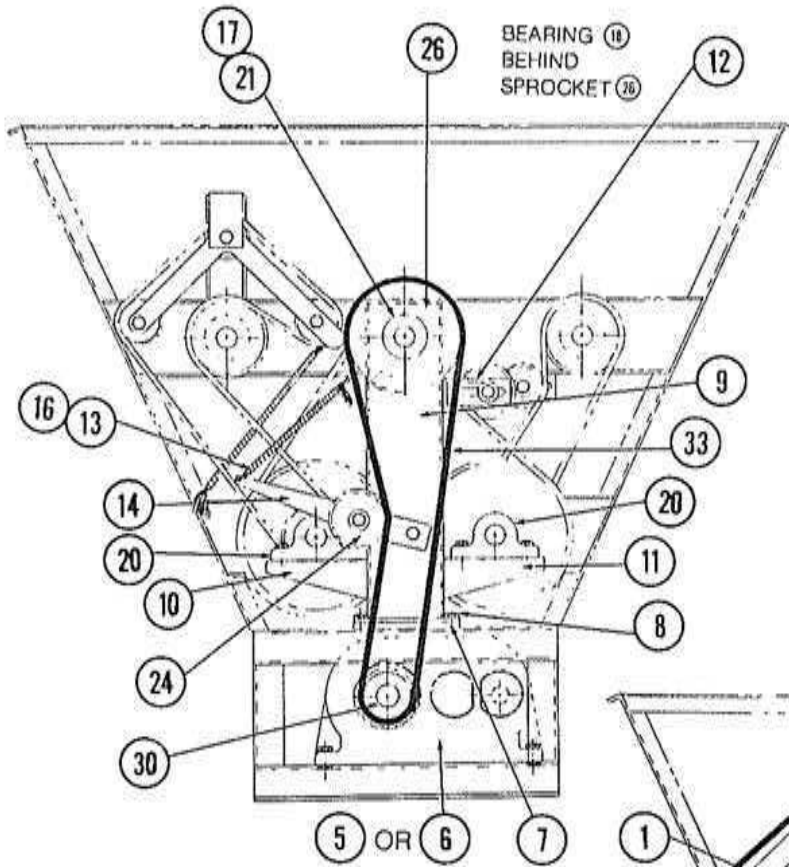

REAR DRIVE SYSTEM
MODELS 302M, 354M, & 302T, 354T 1000 RPM

ITEM	PART #	DESCRIPTION	QTY.
1	A10653	Flanged Shaft 2 7/16 x 9 3/4 Lg.	2
*2	A13531	Flanged Shaft 2 7/16 x 16 7/8 Lg.	2
*2	A14731	Flanged Shaft 2 15/16 x 12 Lg. w/o pillow block bearing	2
*3	13532	Stub Shaft 2 7/16 x 19 Lg.	1
*3	12678	Stub Shaft 2 15/16 x 20 Lg.	1
4	A12815	Gear Box Bracket Ass'y	1
5	100971	Gear Box #58055	
6	101401	Gear Box #5809	
7	13299	Bottom Support Channel Plate	1
8	13381	Top Support Channel	1
9	13298	Support Channel	1
10	13314	Bearing Support Angle (left)	1
11	13387	Bearing Support Angle (right)	1
12	A12499	Idler Sprocket Mount Ass'y	1
13	10820	Auger Reversing Ass'y	2
14	A10209	Tightener, Chain	1
15	A12713	Chain Tightener Ass'y	1
16	100447	Spring, 1 1/4 x 11 3/4	2
17	10984	Key, Square, 5/8 x 3	5
*18	100051	Bearing (FB900 x 2 7/16)	2
*18	101410	Bearing (RPB 2 15/16) w/o pillow block bearing	2
*19	100048	Bearing, Flanged (2 7/16)	4
*19	101707	Bearing, Flanged (2 15/16) w/o pillow block bearing	4
20	100050	Bearing, Pillow Block (2")	4
21	100078	Bushing (R1 x 2 7/16)	7
*21	100066	Bushing (R1 x 2 15/16) w/o pillow block bearing	
22	A13374	Idler Sprocket (HB80 A12 x 1")	*1
23	A13375	Idler Sprocket (HB100 A12 x 1")	2
24	A13376	Idler Sprocket (HB80 A18 x 1")	1
25	100073	Sprocket (H80 R40)	2
26	100103	Sprocket (H100 R48)	1
27	100076	Sprocket (HDS 100 R17)	1
28	100074	Sprocket (HDS 100 R48 / 80 R24 (R.H.))	1
29	100742	Sprocket (HDS 100 R48 / 80 R24 (L.H.))	1
30	100969	Sprocket (H100 B14 x 2 3/4")	1
31	101991	Roller Chain (#80 x 136 Pitch)	1
32	10619	Roller Chain (#80 x 84 Pitch)	1
33	11300	Roller Chain (#80 x 158 Pitch)	1
34	10620	Roller Chain (#100 x 93.75 Pitch)	2

REAR DRIVE SYSTEM LATER STYLE 302M, 354M & 302T, 354T

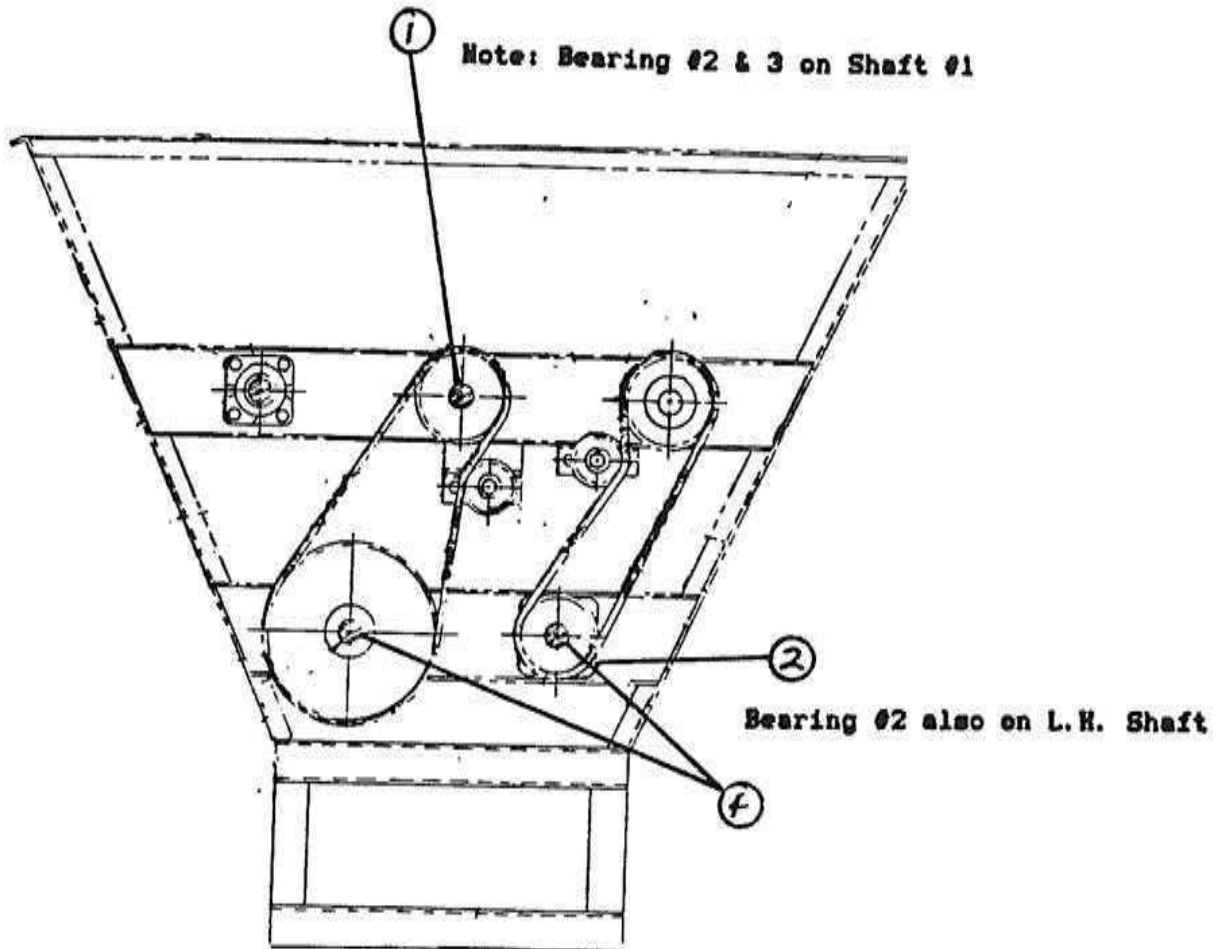

ITEM NO	PART NO	DESCRIPTION	QTY REQD
1	12678	STUB SHAFT	1
2	101707	2 15/16 BEARING, FLANGED	3
3	101410	2 15/16 BEARING, SPLIT PILLOW BLOCK	1
4	A14731	FLANGED STUB SHAFT	2

NOTE: PLEASE CHECK SHAFT O.D. BEFORE ORDERING PARTS.
NOTE: LOWER SHAFTS DO NOT HAVE OUTBOARD PILLOW BLOCKED BEARINGS.

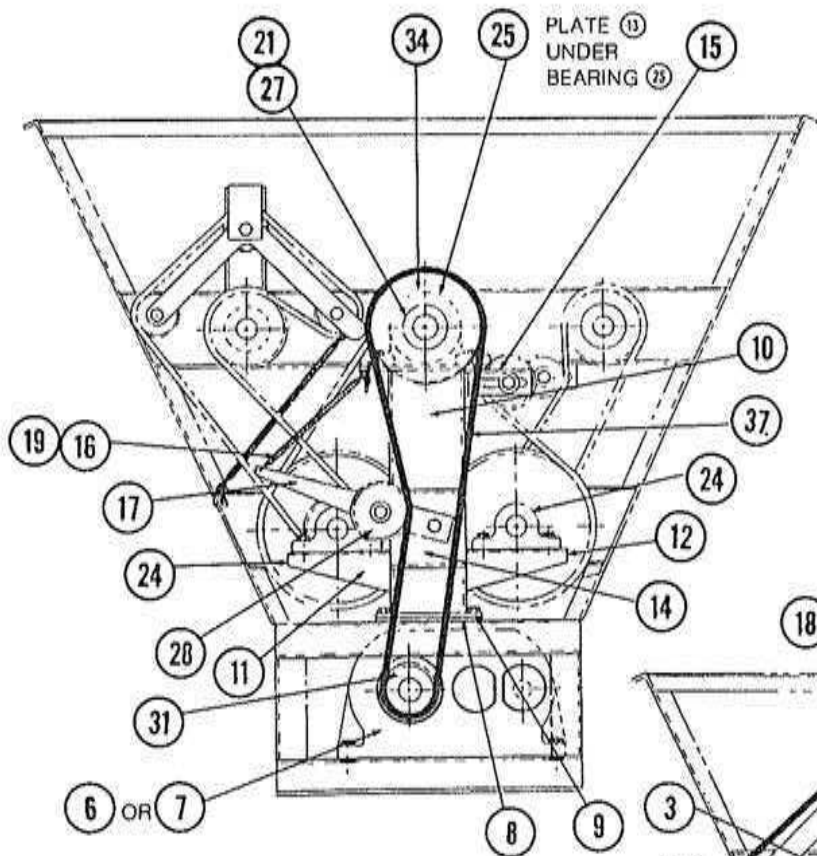

REAR DRIVE SYSTEM
 FOR MODELS 354MS, 406M, 406T & 458M

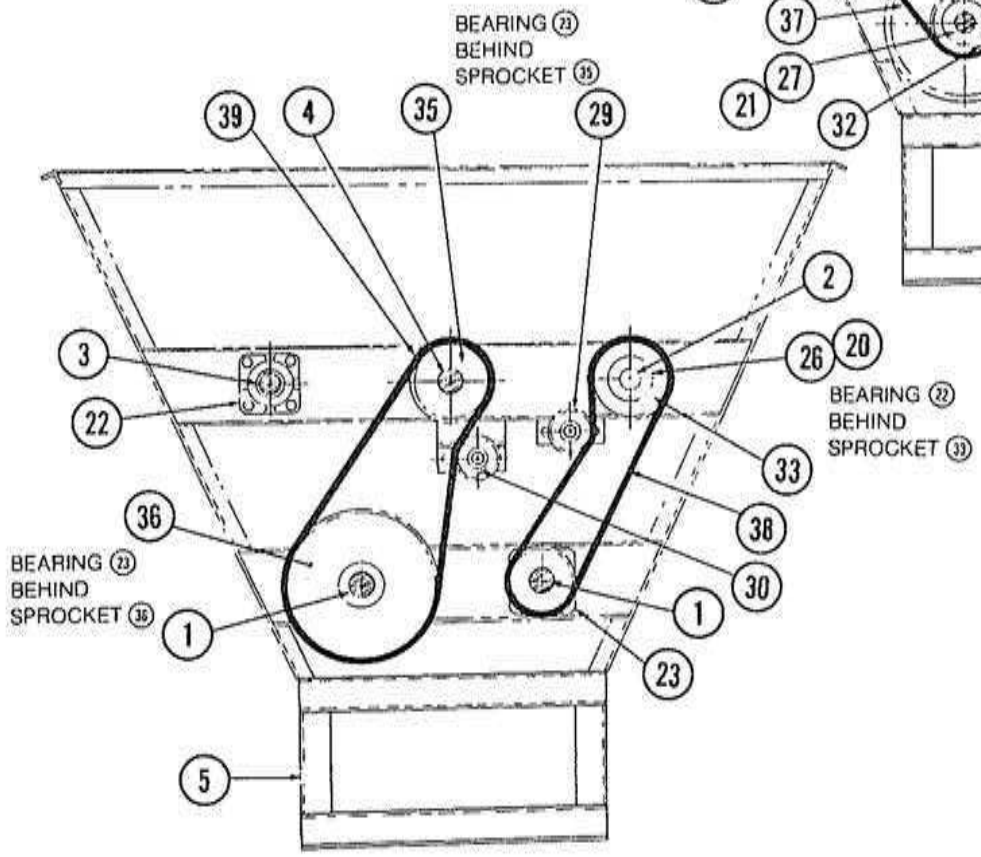
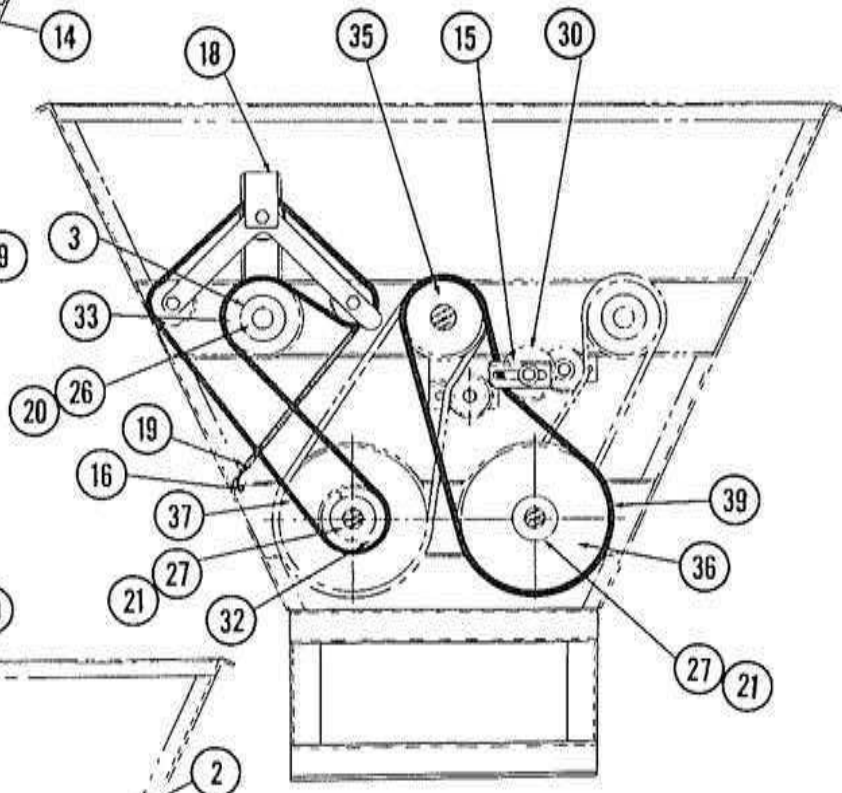

REAR DRIVE SYSTEM
MODELS 354MS, 406M, 406T & 458M

ITEM	PART #	DESCRIPTION	QTY.
1	A10813	Flanged Shaft 2 15/16 x 16 3/4 Lg.	2
2	A10653	Flanged Shaft 2 7/16 x 9 3/4 Lg.	1
3	A12814	Flanged Shaft 2 7/16 x 12 Lg.	1
4	12678	Stub Shaft 2 15/16 x 20 Lg.	1
5	A12815	Gear Box Bracket Ass'y	1
6	100971	Gear Box #58055	
7	101401	Gear Box #5809	
8	13299	Bottom Support Channel Plate	1
9	13381	Top Support Channel	1
10	13598	Support Channel	1
11	13314	Bearing Support Angle (left)	1
12	13387	Bearing Support Angle (right)	1
13	13599	Bearing Support Plate	1
14	13602	Chain Tightener Support Channel	1
15	A12499	Idler Sprocket Mount Ass'y	1
16	10820	Tightener Chain	2
17	A10209	Chain Tightener Ass'y	1
18	A12714	Auger Reversing Ass'y	1
19	100447	Spring 1 1/4 x 11 3/4 Lg.	2
20	10984	Key, Square 5/8 x 3 Lg.	2
21	10985	Key, Square 3/4 x 4 Lg.	3
22	100048	Bearing Flanged (2 7/16)	2
23	100067	Bearing (FB 2 15/16)	3
24	100122	Bearing (PB 900 2 7/16)	2
25	101410	Bearing (RPB 2 15/16)	1
26	100078	Bushing (R1 x 2 7/16)	2
27	100066	Bushing (R1 x 2 15/16)	3
28	A13378	Idler Sprocket (HB100 A16 x 1")	1
29	A13375	Idler Sprocket (HB100 A12 x 1")	1
30	A13377	Idler Sprocket (HB120 A12 x 1")	2
31	101608	Sprocket (H100 B17 x 2 3/4)	1
32	100139	Sprocket (100 B15 x 2 15/16)	2
33	101411	Sprocket (H100 R24)	2
34	100103	Sprocket (H100 R48)	1
35	100393	Sprocket (H120 B16 x 2 15/16)	2
36	100087	Sprocket (H120 R40)	2
37	11300	Roller Chain (#100 x 132.5" Lg.)	2
38	10620	Roller Chain (#100 x 93.75 " Lg.)	1
39	11302	Roller Chain (#120 x 96" Lg.)	2

FRONT SYSTEM

FOR 302T-354T, 406T, 302M-354M, 354MS-406M, 458M

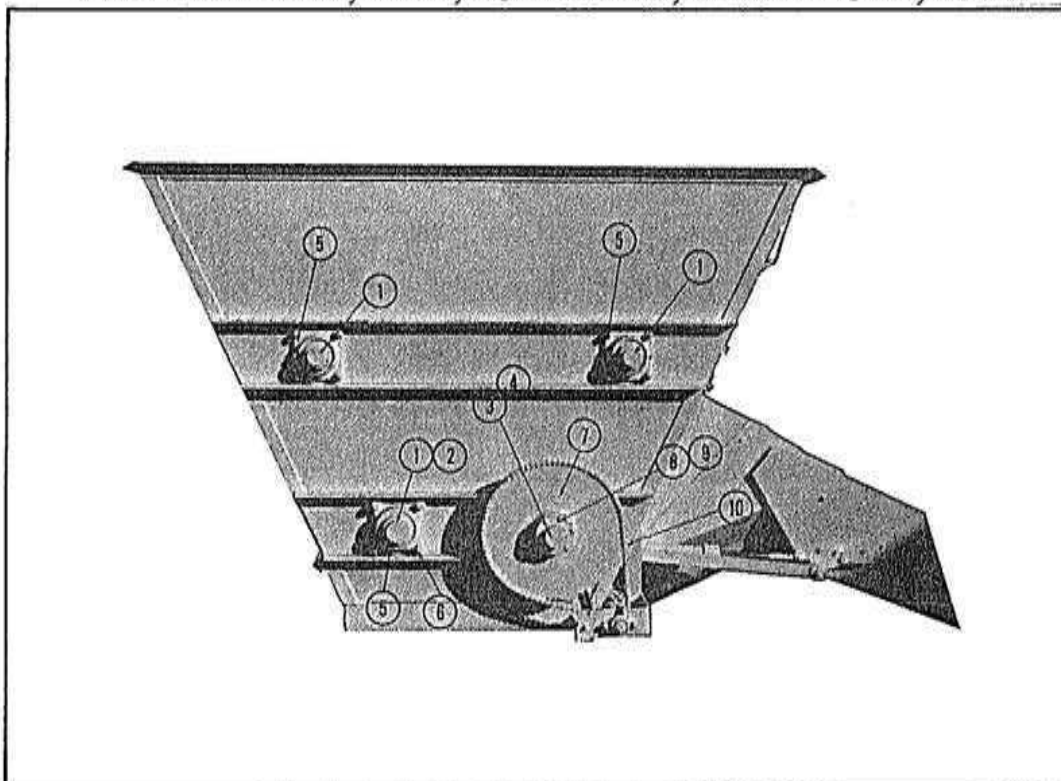

ITEM	PART #	DESCRIPTION	302T	354MS
			302M	406T
			354T	406M
			354M	458M
1	A10710	Flanged Stub Shaft (2-7/16 DIA x 6-3/4 lg.)	3	2
2	A10811	Flanged Stub Shaft (2-15/16 DIA x 7 lg.)	-	1
3	A10653	Flanged Stub Shaft (2-7/16 DIA x 9-3/4 lg.)	1	-
4	A10812	Flanged Stub Shaft (2-15/16 DIA x 9 3/4 lg.)	-	1
5	100048	Flanged Bearing (2 7/16)	4	2
6	100067	Flanged Bearing (FB900 2-15/16)	-	2
7	101213	Sprocket (H60 R80)	1	1
8	100078	Sprocket Bushing (R1 x 2-7/16 DIA.)	1	-
9	100066	Sprocket Bushing (R1 x 2-15/16 DIA.)	-	1
10	12826	Chain, Discharge Drive (#60 x 66" lg.)	1	1
11	101314	Idler Sprocket (H60 B13 w/5/8 brg.)	1	1
12	Refer to page 40 for clutch repair breakdown			

HARSH

MOBILE MIX

**MAIN DRIVE SYSTEMS
FOR**

300F-350F, 300M - 350M, 350MS - 400M, 300R - 350R
FRONT AND REAR

FRONT SYSTEM

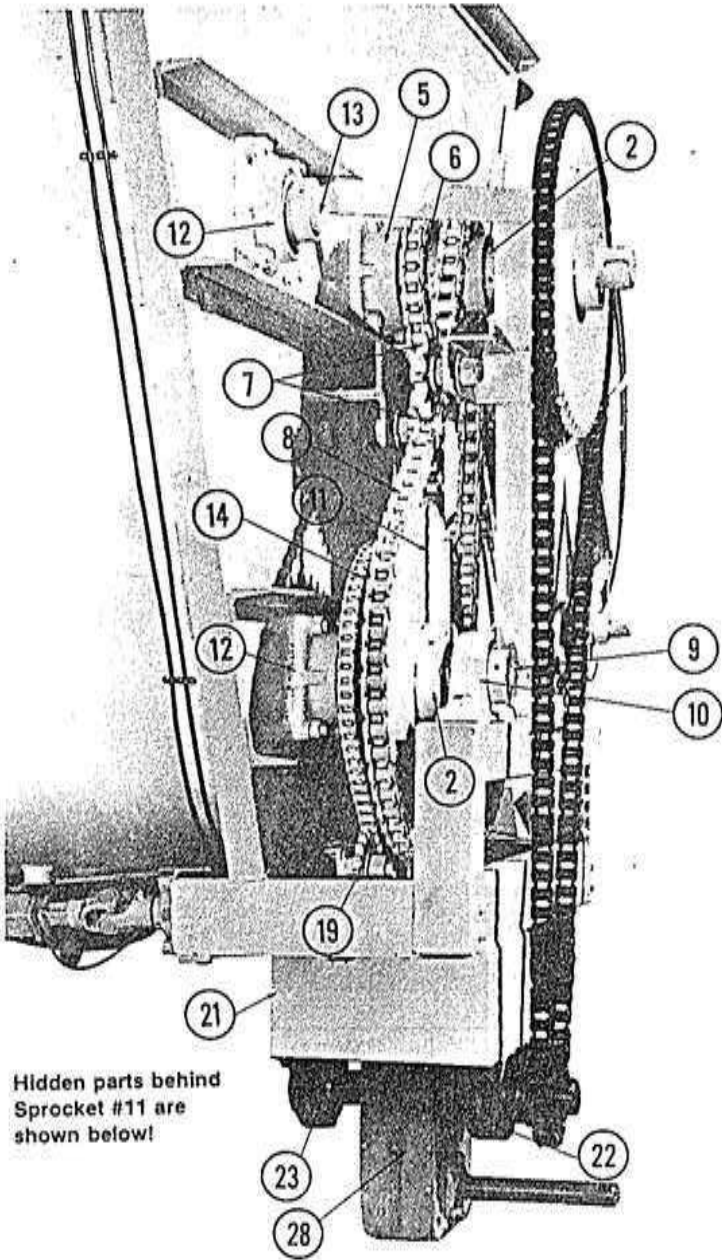

Hidden parts behind Sprocket #11 are shown below!

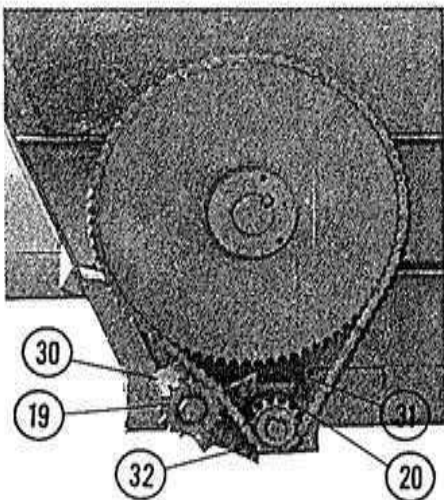
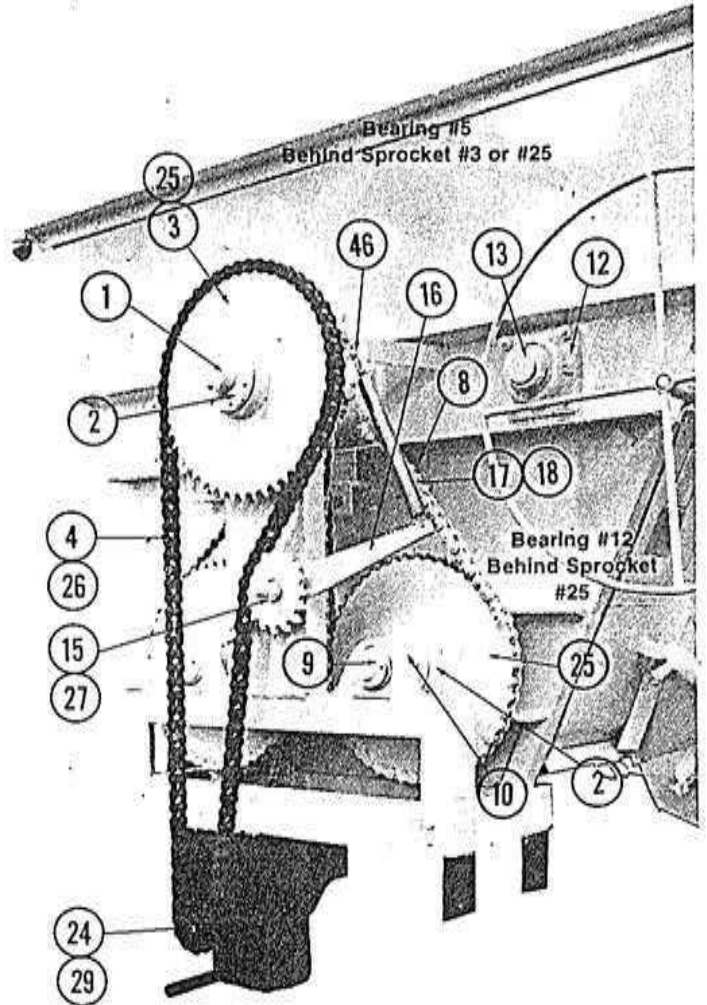

THIS PICTURE SHOWS PARTS THAT ARE CONCEALED BEHIND SPROCKET #11

300F - 350F

ITEM NUMBER	PART NUMBER	DESCRIPTION	NO. REQUESTED	
			MODEL 300F	MODEL 350F
1	10548	Top shaft (2 7/16" Dia. x 16" Lg.)	1	1
2	100078	Sprocket bushing (2 7/16" Dia.)	4	4
3	100081	Sprocket (H80 R60)	1	-
4	10627	Main drive chain (#80 x 132" Lg.)	1	-
5	100051	Flanged bearing (2 7/16" Dia.) FB900	2	2
6	100076	Sprocket (DS100 R17)	1	1
7	A13375	Idler sprocket (HB100 A12 x 1")	2	2
8	10620	Drive chain (#100 x 96 1/4")	2	2
9	A10652	Flanged stub shaft (2 7/16" Dia. x 13 3/4" Lg.)	2	2
10	100050	Pillow block bearing (2" Dia.)	2	2
11	101212	Sprocket (DS100 R48/R60 R80) - Dual auger discharge	1	1
11	100083	Sprocket (DS100 R48/R60 R60) - Single auger discharge	1	1
12	100048	Flanged bearing (2 7/16" Dia.)	4	4
13	A10710	Flanged stub shaft (2 7/16" Dia. x 6-3/4" Lg.)	2	2
14	12826	Discharge drive chain (#60 x 66" Lg.) - Dual auger disch.	1	1
14	10618	Discharge drive chain (#60 x 57" Lg.) - Single auger disch.	1	1
15	A13376	Idler sprocket (HB80 A18 x 1")	1	1
16	A10209	Chain tightener assy.	1	1
17	100447	Tension spring (1 1/4" Dia. x 11 3/4" Lg.)	1	1
18	10820	Tightener chain	1	1
19	A13373	Idler sprocket (HB60 A16 x 1")	1	1
20	100072	Sprocket (H60 B13 x 1 1/4")	1	1
21	A10692	BJ Gear box mounting bracket	1	1
22	100057	Pillow block bearing (1 15/16" Dia.) PB900	1	1
23	100052	Pillow block bearing (1 15/16" Dia.)	1	1
24	100100	Sprocket (H80 B14 x 1 15/16" Dia.)	1	-
25	100103	Sprocket (H100 R48)	1	2
26	11300	Main drive chain (#100 x 132 1/2" Lg.)	-	1
27	A13378	Idler sprocket (HB100 A16 x 1")	-	1
28	100441	BJ48A Gear box	1	1
28	100299	BJ48 Gear box	1	1
29	100098	Sprocket (H100 B11 x 1 15/16")	-	1
*30	A12489	Idler sprocket mount assy.--Bolt @ center (DAD)	1	1
*30	A10210	Idler sprocket mount assy.--Bolt @ end (SAD)	1	1
31	100446	Spring (1 1/8" Dia. x 5 1/2" Lg.)	1	1
32	100334	Shoulder screw (3/8" x 16 UNC)	1	1
33	10550	Discharge drive shaft (1 1/4" x 16 1/2")	1	1
34	100053	Flanged bearing (1 1/4")	1	1

REAR SYSTEM

300F - 350F

REVERSER
OPTION

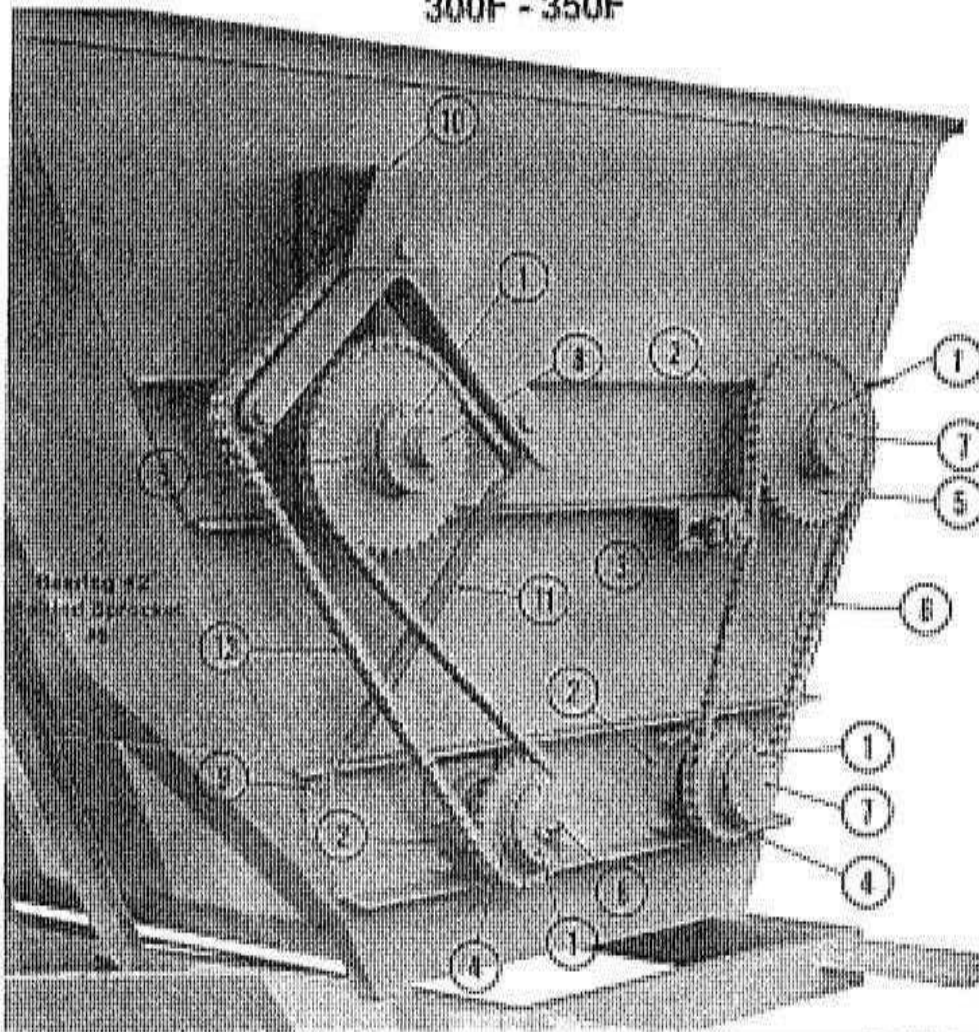

ITEM NUMBER	PART NUMBER	DESCRIPTION	NUMBER REQUIRED			
			MODEL 300F		MODEL 350F	
			W/REV.	W/OUT REVERSER.	W/REV.	W/OUT REVERSER.
1	100078	Sprocket bushing (2 7/16" Dia.) R1 x 2 7/16"	4	4	4	4
2	100048	Flanged bearing (2 7/16" Dia.)	4	4	4	4
3	A13374	Idler sprocket (HB80 A12 x1")	1*	0	1*	0
3	A13376	Idler sprocket (HB80 A18 x 1")	0	1	0	1
4	100120	Sprocket (H80 R24)	2	2	2	2
5	100073	Sprocket (H80 R40)	2	2	2	2
6	10619	Chain rear drive (#80 x 84" Lg.)	1	2	1	2
7	A10653	Flanged stub shaft (2 7/16" Dia. x 9 3/4" Lg.)	2	4	2	4
8	A10624	Flanged stub shaft (2 7/16" Dia. x 12" Lg.)	2	0	2	0
9	12495	Tightener chain	1	0	1	0
10	A12713	Auger reversing assy.	1*	0	1*	0
11	100447	Spring (1 1/4" Dia. x 11 3/4" Lg.)	1	0	1	0
12	12493	Chain rear drive (#80 x 135" Lg.)	1	0	0	0

* 3 Sprockets included with item 10 Auger Reversing Assy.

REAR SYSTEM

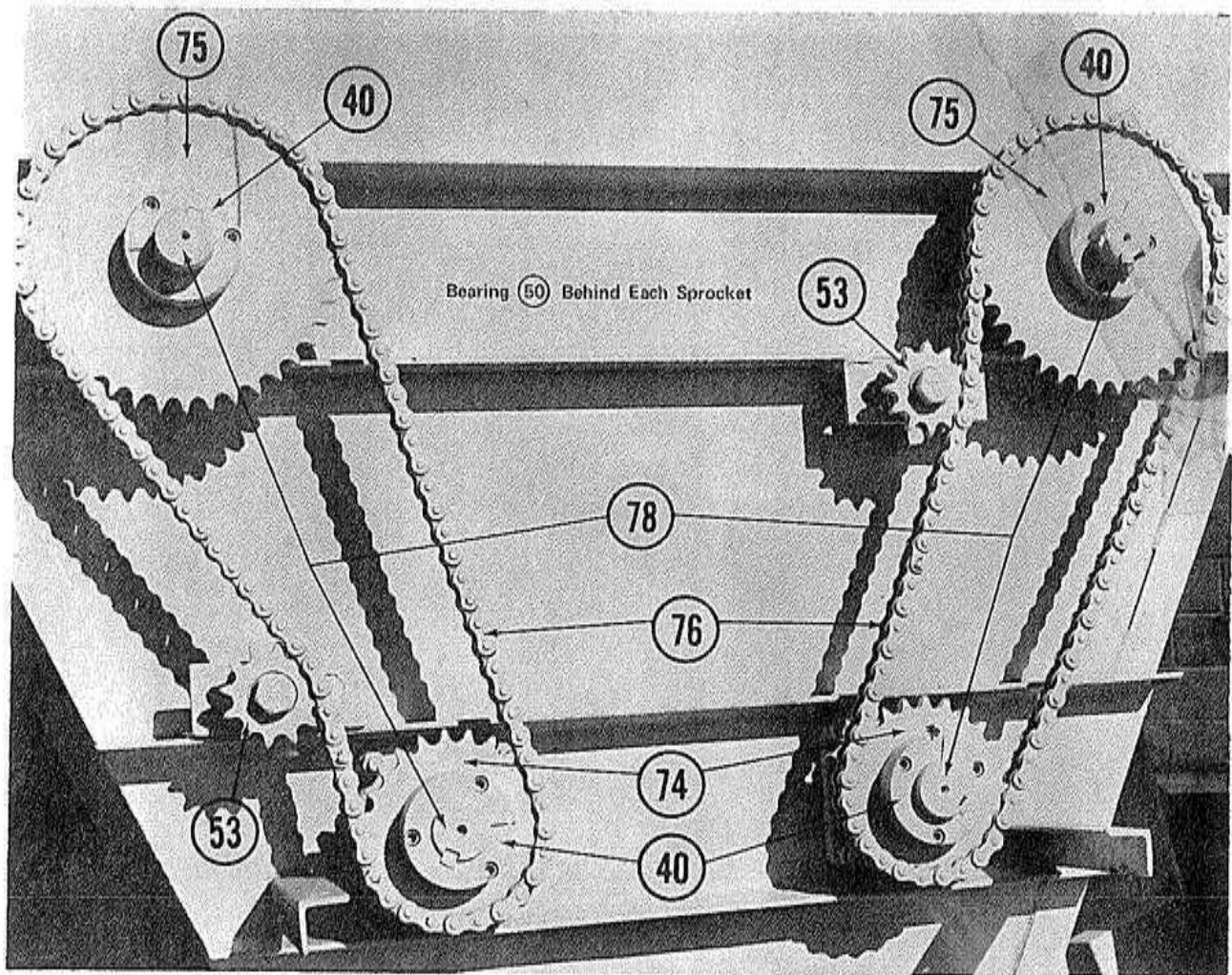

ITEM NO.	PART NO.	DESCRIPTION	NO. REQ'D.	
			MODEL 300F	MODEL 350F
40	100078	Sprocket Bushing (2-7/16" Dia.)	4	4
50	100048	Flanged Bearing (2-7/16" Dia.)	4	4
53	A15376	Idler Sprocket (HB80 A18 x 1")	2	2
74	100120	Sprocket (H80 R24)	2	2
75	100073	Sprocket (H80 R40)	2	2
76	10619	Chain Rear Drive (#80 x 84" Lg.)	2	2
78	A10653	Flanged Stud Shaft (2-7/16" Dia. x 9-3/4" Lg.)	4	4

REAR SYSTEM

BEARINGS (43) ON EACH
END OF SHAFT (39)

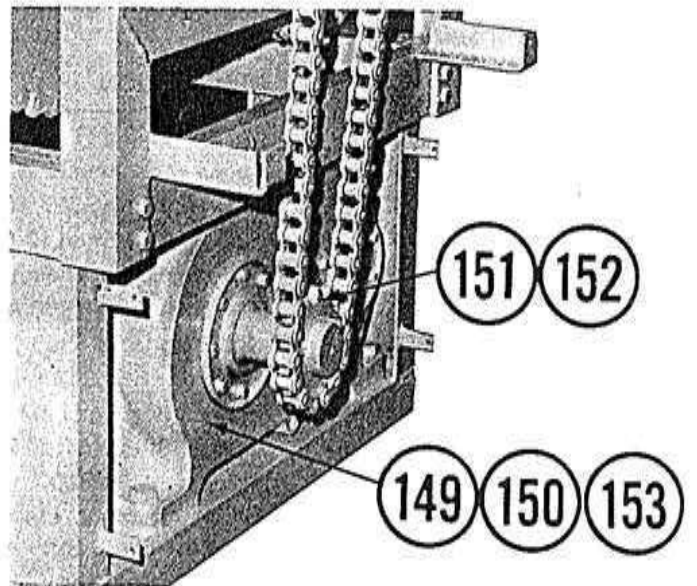
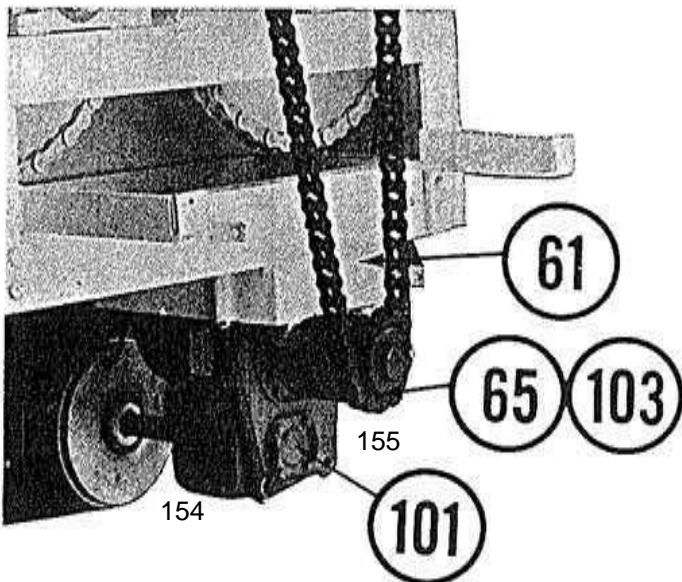
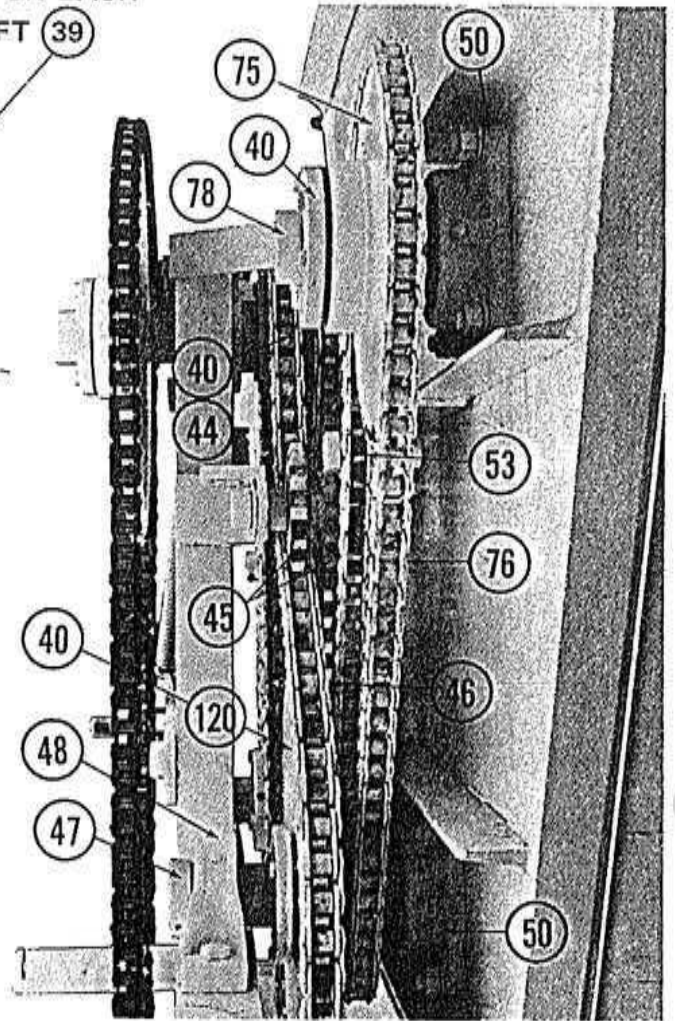
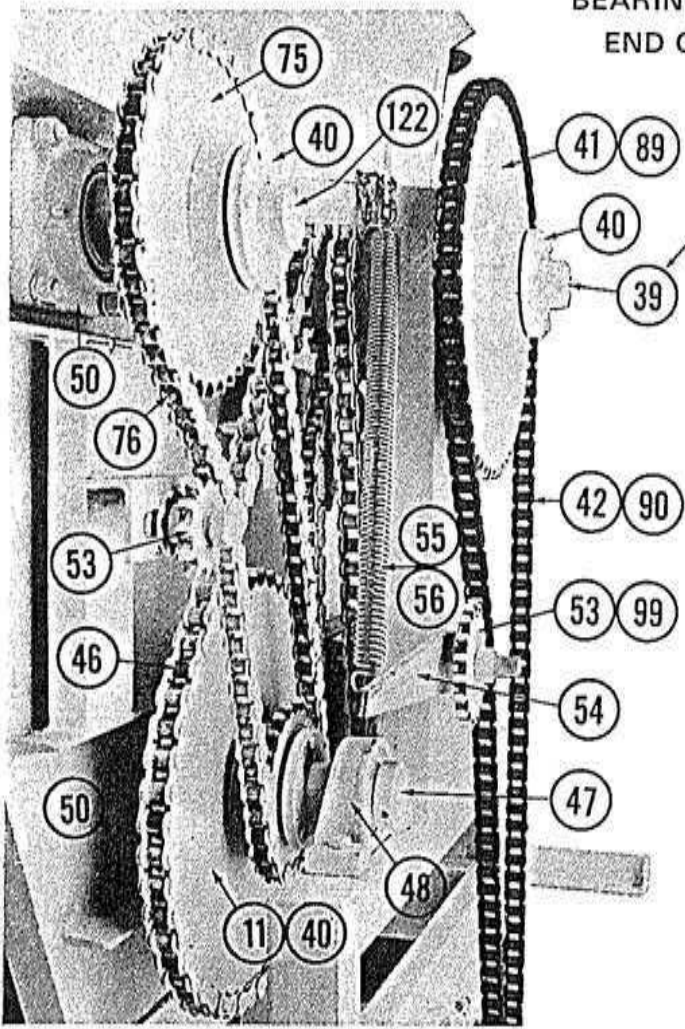

REAR SYSTEM

300M - 350M

With out top left hand auger reverser

ITEM NO.	PART NO.	DESCRIPTION	300M and 350M				
			58055 Gearbox	8309 Gearbox (LH)	8309 Gearbox (RH)	BJ48A Gearbox 300M	BJ48A Gearbox 350M
11	100742	Sprocket (HDS100R48/80R24) (LH)	1	1	1	1	1
39	10548	Top shaft (2 7/16" Dia. x 16" Lg.)	1	1	1	1	1
40	100078	Sprocket bushing (2 7/16" Dia.)	6	6	6	6	6
*41	100081	Sprocket (H80 R60)	1	-	-	-	-
*42	10627	Main drive chain (#80 x 132" Lg.)	1	-	-	-	-
43	100051	Bearing, flanged (2 7/16" Dia.)	2	2	2	2	2
44	100076	Sprocket (HDS100R17)	1	1	1	1	1
45	A13375	Idler sprocket (HR100A12 x 1")	2	2	2	2	2
46	10620	Main drive chain (#100 x 96 1/2" Lg.)	2	2	2	2	2
47	A10652	Flanged stub shaft (2 7/16" Dia. x 13 3/4" Lg.)	2	2	2	2	2
48	100050	Bearing, pillow block (2" Dia.)	2	2	2	2	2
50	100048	Bearing flanged (2 7/16" Dia.)	4	4	4	4	4
*53	A13376	Idler sprocket (HB80 A18 x 1")	3	2	2	2	2
54	A10209	Chain tightener assembly	1	1	1	1	1
55	100447	Tension spring (1 1/4" Dia x 11 3/4" Lg.)	1	1	1	1	1
56	10820	Tightener chain	1	1	1	1	1
61	A10692	BJ48A Gear box mounting brackets	1	-	-	-	-
*65	100100	Sprocket (H80 B14 x 1 15/16" Dia.)	1	-	-	-	-
75	100073	Sprocket (H80 R40)	2	2	2	2	2
76	10619	Drive chain (#80 x 84" Lg.)	2	2	2	2	2
78	A10653	Flanged stub shaft (2 7/16" Dia. x 9 3/4" Lg.)	1	1	1	1	1
89	100103	Sprocket (H100 R48)	-	1	1	1	1
90	11300	Main drive chain (#100 x 133 3/4" Lg.)	-	1	1	1	1
99	A13578	Idler sprocket (HB100 A16 x 1")	-	1	1	1	1
101	100299	BJ48 Gear box	1	-	-	-	1
101	100441	BJ48A Gear box	1	-	-	-	1
103	100098	Sprocket (H100 B11 x 1 15/16" Dia.)	-	-	-	-	1
120	100074	Sprocket (HDS100R48/80R24) (RH)	1	1	1	1	1
122	A10624	Flanged stub shaft (2 7/16" Dia. x 12" Lg.)	1	1	1	1	1
149	100807	8309 Dorris Gear box (RH)	-	-	1	-	-
150	100808	8309 Dorris Gear box (LH)	-	1	-	-	-
151	100823	Sprocket (H100 B17 x 3")	-	1	1	-	-
152	100969	Sprocket (H100 B14 x 2 3/4")	-	-	-	1	-
153	100971	58055 Dorris Gear box	-	-	-	1	-

*Alternate as a group. (300M Only) Items 41, 42, 53, and 65.

89	100103	Sprocket (H100 R48)	1	-	-	-	-
90	11300	Main drive chain (#100 x 133 3/4" Lg.)	1	-	-	-	-
99	A13378	Idler sprocket (HB100 A16 x 1")	1	-	-	-	-
103	100098	Sprocket (H100 B11 x 1 15/16" Dia.)	1	-	-	-	-
154	100057	Bearing PB900 1 15/16"	-	-	-	-	-
155	100052	Bearing 1 15/16" pillow block	-	-	-	-	-

REAR SYSTEM

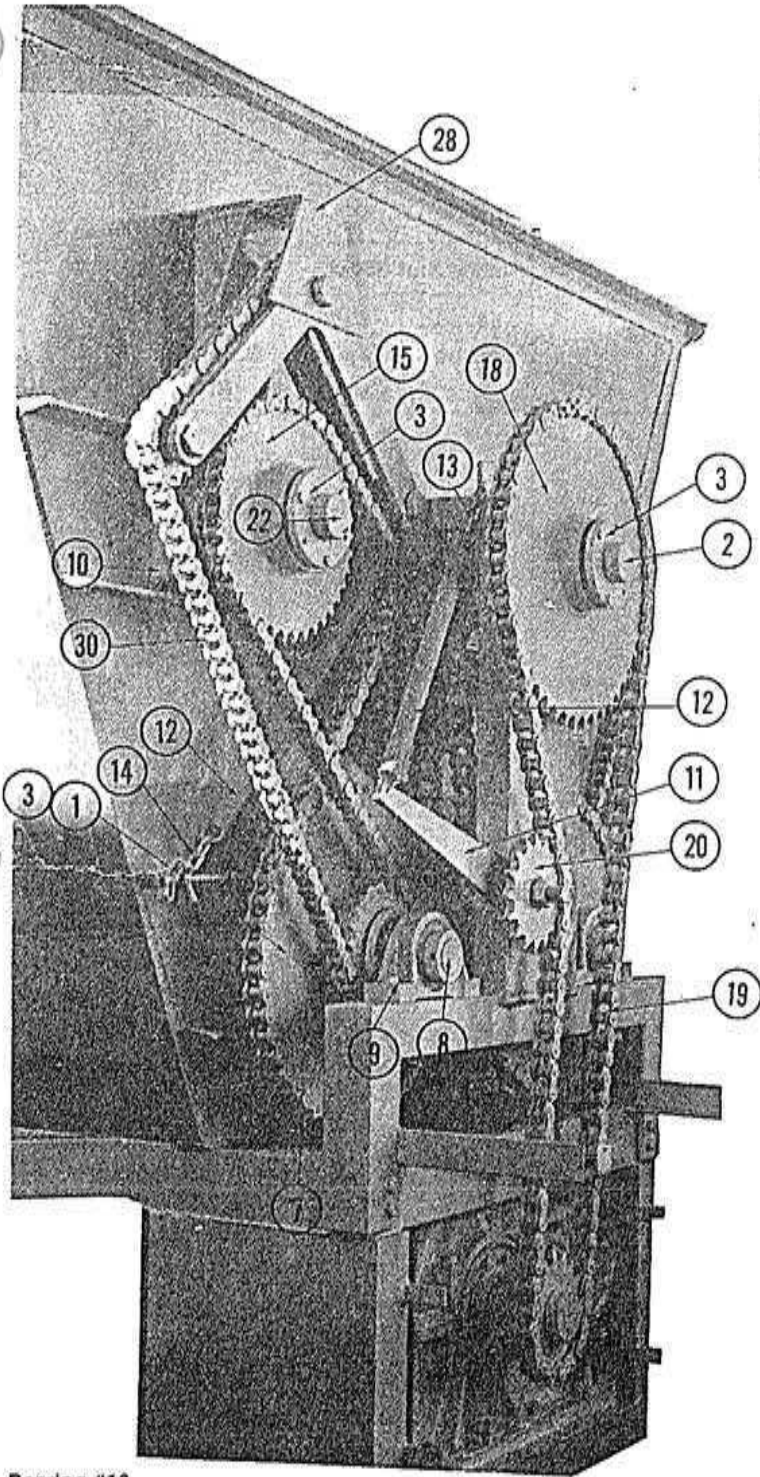

Bearing #10
Behind Sprocket #1

Bearing #4 on
each end of
shaft #2

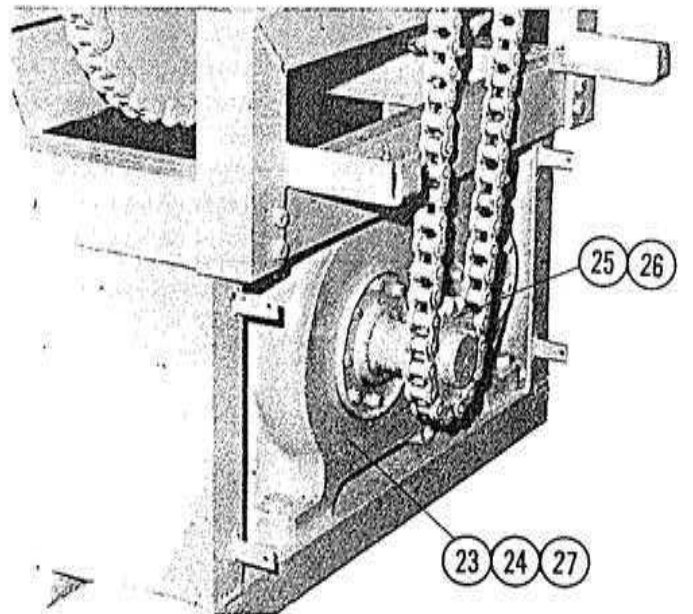
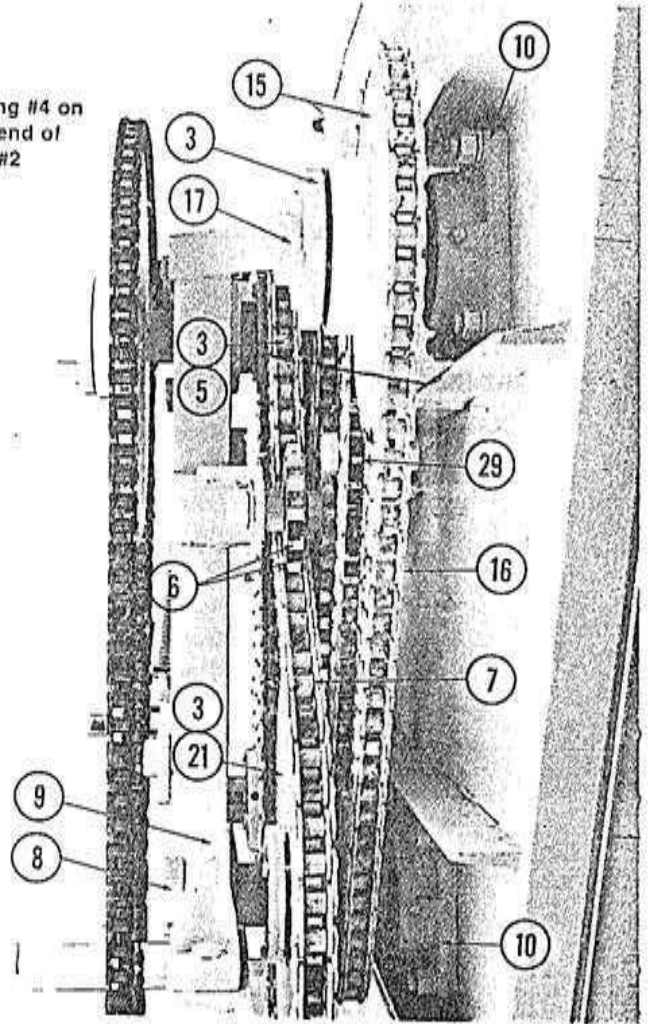

REAR SYSTEM
300M - 350M
With top left hand auger reverser

ITEM NUMBER	PART NUMBER	DESCRIPTION	300M and 350M		
			58055 Gearbox	8309 Gearbox (LH)	8309 Gearbox (RH)
1	100742	Sprocket (HDS100R48/80R24) (LH)	1	1	1
2	10548	Top shaft (2 7/16" Dia. x 16" Lg.)	1	1	1
3	100078	Sprocket bushing (2 7/16" Dia.)	6	6	6
4	100051	Bearing, flanged (2 7/16" Dia.)	2	2	2
5	100076	Sprocket (HDS100R17)	1	1	1
6	A13375	Idler sprocket (HB100 A12 x 1")	2	2	2
7	10620	Main drive chain (#100 x 96 1/2" Lg.)	2	2	2
8	A10652	Flanged stub shaft (2 7/16" Dia x 13 3/4" Lg.)	2	2	2
9	100050	Bearing, pillow block (2" Dia.)	2	2	2
10	100048	Bearing, flanged (2 7/16" Dia.)	4	4	4
11	A10209	Chain tightener assembly	1	1	
12	100447	Tension spring (1 1/4 Dia. x 11 3/4" Lg.)	2	2	2
13	10820	Tightener chain	1	1	1
14	12495	Tightener chain	1	1	1
15	100073	Sprocket (H80 R40)	2	2	2
16	10619	Drive chain (#80 x 84" Lg.)	1	1	1
17	A10653	Flanged stub shaft (2 7/16" Dia. x 9 3/4" Lg.)	1	1	1
18	100103	Sprocket (H100 R48)	1	1	1
19	11300	Main drive chain (#100 x 132 1/2" Lg.)	1	1	1
20	A13378	Idler sprocket (HB100 A 16 x 1")	1	1	1
21	100074	Sprocket (HDS100R48/80R24) (RH)	1	1	1
22	A10624	Flanged stub shaft (2 7/16" Dia. x 12" Lg.)	1	1	1
23	100807	8309 Dorris Gear box (RH)	-	-	1
24	100808	8309 Dorris Gear box (LH)	-	1	1
25	100823	Sprocket (H100 B17 x 3")	-	1	1
26	100969	Sprocket (H100 B14 x 2 3/4")	1	-	-
27	100971	58055 Dorris Gear box	1	-	-
28	A12713	Auger reversing assy.	1*	1*	1*
29	A13374	Idler sprocket (HB80 A12 x 1")	1*	1*	1*
30	12493	Drive chain (#80 x 135" Lg.)	1	1	1

*3 Sprockets included with Auger Reversing Assy. A12713

REAR SYSTEM
350MS - 400M

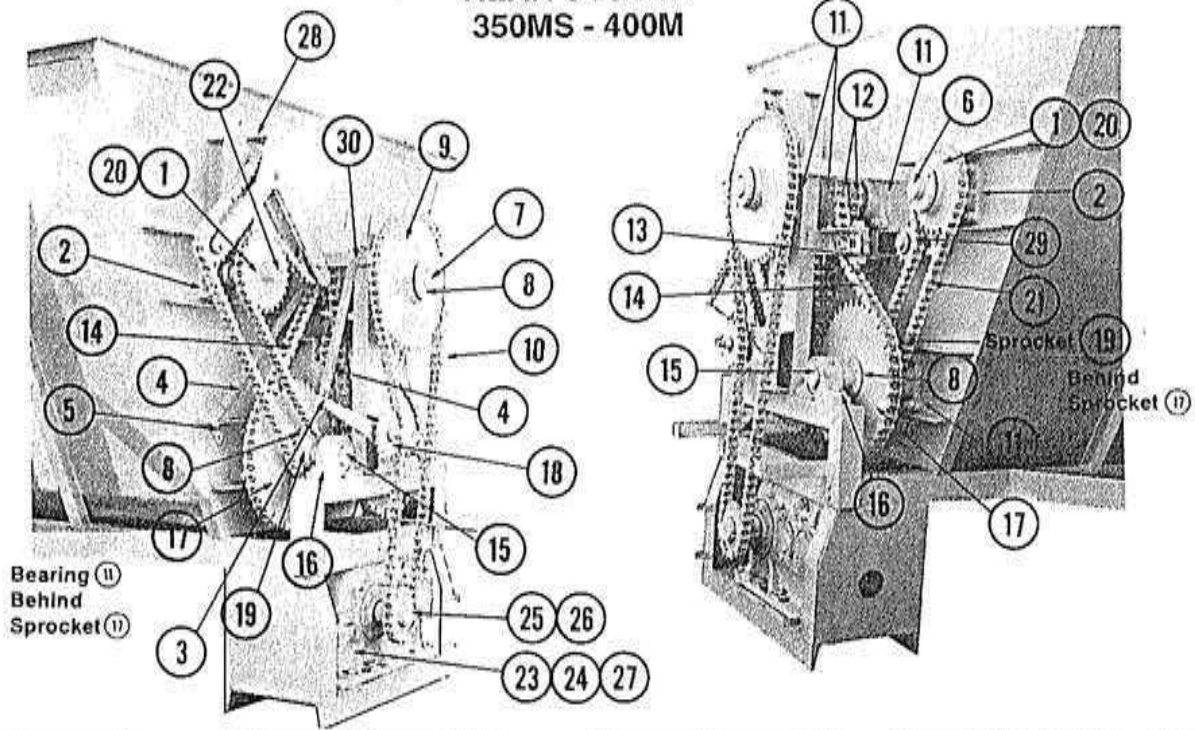

ITEM NUMBER	PART NUMBER	DESCRIPTION	NO. REQ'D					
			8309 Gearbox (LH)		8309 Gearbox (RH)		58055 Gearbox	
			W/REV	W/OUT REV.	W/REV	W/OUT REV.	W/REV	W/OUT REV.
1	100078	Sprocket bushing (2 7/16" Dia.)	2		2		2	
2	100048	Flanged bearing (2 7/16" Dia.)	2		2		2	
3	A10209	Chain tightener assembly	1		1		1	
4	100447	Tension spring (1 1/4" Dia. x 11 3/4" Lg.)	2		2		2	
5	10820	Tightener chain	1		1		1	
6	A10653	Flanged stub shaft (2 7/16" Dia. x 9 3/4" Lg.)	1		1		1	
7	12678	Shaft (2 15/16" Dia. x 20" Lg.)	1		1		1	
8	100066	Sprocket bushing (2 15/16" Dia.)	3		3		3	
9	100103	Sprocket (H100 R48)	1		1		1	
10	11300	Main drive chain (#100 x 132 1/2" Lg.)	1		1		1	
11	100067	Flanged bearing (2 15/16" Dia.)	5		5		5	
12	100393	Sprocket (H120 B16 x 2 15/16" Dia.)	2		2		2	
13	A13377	Idler sprocket (HB120 A12 x 1")	2		2		2	
14	11302	Main drive chain (#120 x 97-1/2" Lg.)	2		2		2	
15	A10813	Flanged stub shaft (2 15/16" Dia. x 16 3/4" Lg.)	2		2		2	
16	100122	Pillow block bearing (2 7/16" Dia.)	2		2		2	
17	100087	Sprocket (H120 R40)	2		2		2	
18	A13378	Idler sprocket (HB100 A 16 x 1")	1		1		1	
19	100139	Sprocket (H100 B15 x 2 15/16" Dia.)	2		2		2	
20	100138	Sprocket (H100 R25)	2		2		2	
21	11301	Drive chain (#100 x 76-1/4" Lg.)	1	2	1	2	1	2
*22	A12814	Flanged stub shaft (2 7/16" Dia. x 12" Lg.)	1		1		1	
*22	A10624	Flanged stub shaft (2 7/16" Dia. x 12" Lg.)	0	1	0	1	0	1
23	100807	Gear box, Dorris 8309 (RH)	-		1		-	
24	100808	Gear box, Dorris 8309 (LH)	1		-		-	
25	100823	Sprocket (H100 B17 x 3" Dia.) (8309)	1		1		-	
26	100969	Sprocket (H100 B14 x 2 3/4" Dia.)	-		-		1	
27	100971	Gear box, Dorris 58055	-		-		1	
28	A12714	Auger reversing assy.	1	0	1	0	1	0
29	A13375	Idler sprocket (HB100 A12 x 1")	1	0	1	0	1	0
30	12495	Tightener chain	1		1		1	
31	7070507	Chain #100 <i>Must check length</i>	AR	0	AR	0	AR	0

REAR SYSTEM

300R - 350R

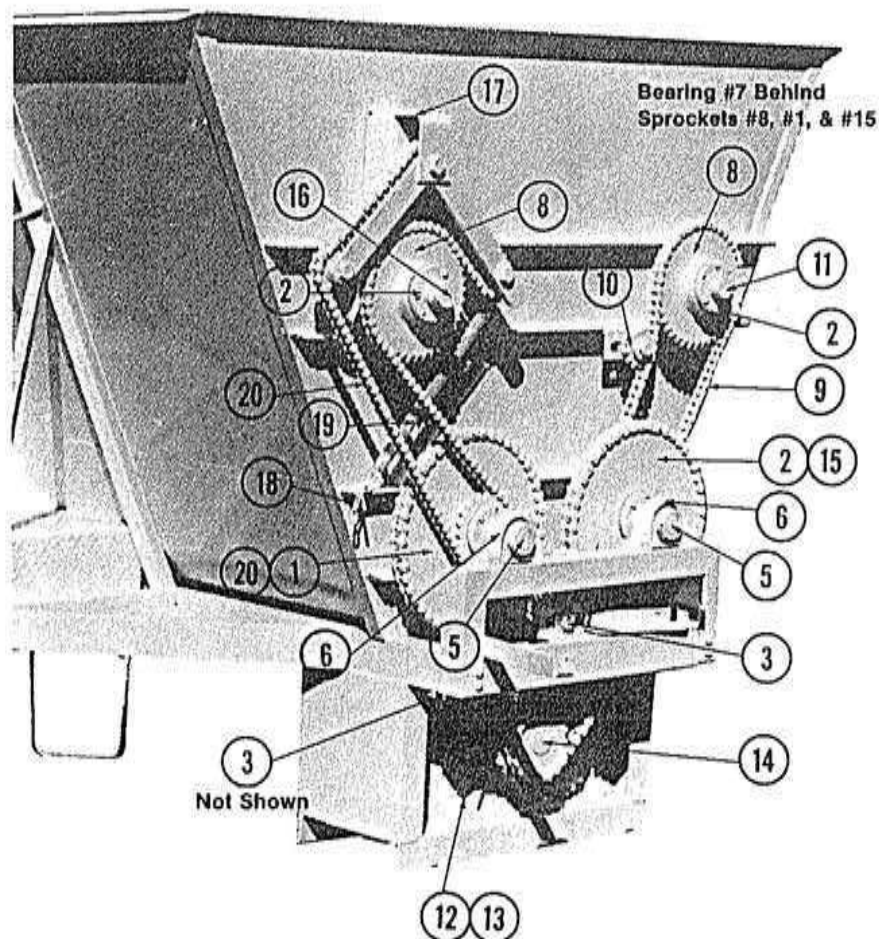

ITEM NO.	PART NO.	DESCRIPTION	NO. REQ'D					
			300R		350R			
			R	L	R	L		
			W/OUT REV.	W/OUT REV.	W/OUT REV.	W/OUT REV.		W/OUT REV.
1	100742	Sprocket (HDS 100R 48/80 R24) (LH)	1	1	1		1	
2	100078	Sprocket bushing (2 7/16" Dia.)	4	4	4		4	
3	A13375	Idler sprocket (HB 100A 12 x 1")	2	2	2		2	
4	10620	Drive chain (#100 x 96 1/4" Lg.)	2	2	2		2	
5	A10652	Flanged stub shaft (2 7/16" x 13 3/4" Lg.)	2	2	2		2	
6	100050	Pillow block bearing (2" Dia.)	2	2	2		2	
7	100048	Flanged bearing (2 7/16" Dia.)	4	4	4		4	
8	100073	Sprocket (H80 R40)	2	2	2		2	
9	10619	Rear drive chain (#80 x 84" Lg.)	1	2	1	2	1	2
10	A13374	Idler sprocket (HB80 A 12 x 1")	1*		1*		1*	
11	A10653	Flanged stub shaft (2 7/16" Dia. x 9 3/4" Lg.)	1	1	1		1	
12	100298	Dorris Gear box (RH) 8324	1	-	1		-	
12	A9581	Gear box - replacement kit	1	-	1		-	
13	100319	Dorris Gear box (LH) 8324	-	1	-		1	
14	100090	Sprocket H100 B19 x 3")	2	2	2		2	
15	100074	Sprocket (HDS 100R 48/80 R24) (RH)	1	1	1		1	
16	10624	Flanged stub shaft (2 7/16" Dia. x 12" Lg.)	1	1	1		1	
17	A12713	Auger reversing assy.	1*	0	1*	0	1*	0
18	12495	Tightener chain	1	0	1	0	1	0
19	100447	Spring (1 1/4" Dia. x 11 3/4" Lg.)	1	0	1	0	1	0
20	12493	Rear drive chain (#80 x 135" Lg.)	1	0	1	0	1	0
21	100324	Bolt (1" - 8 x 3")	1	1	1		1	

* 3 Sprockets included with item 17 Auger Reversing Assy.

300R & 350R

REAR SYSTEM WITHOUT REVERSER

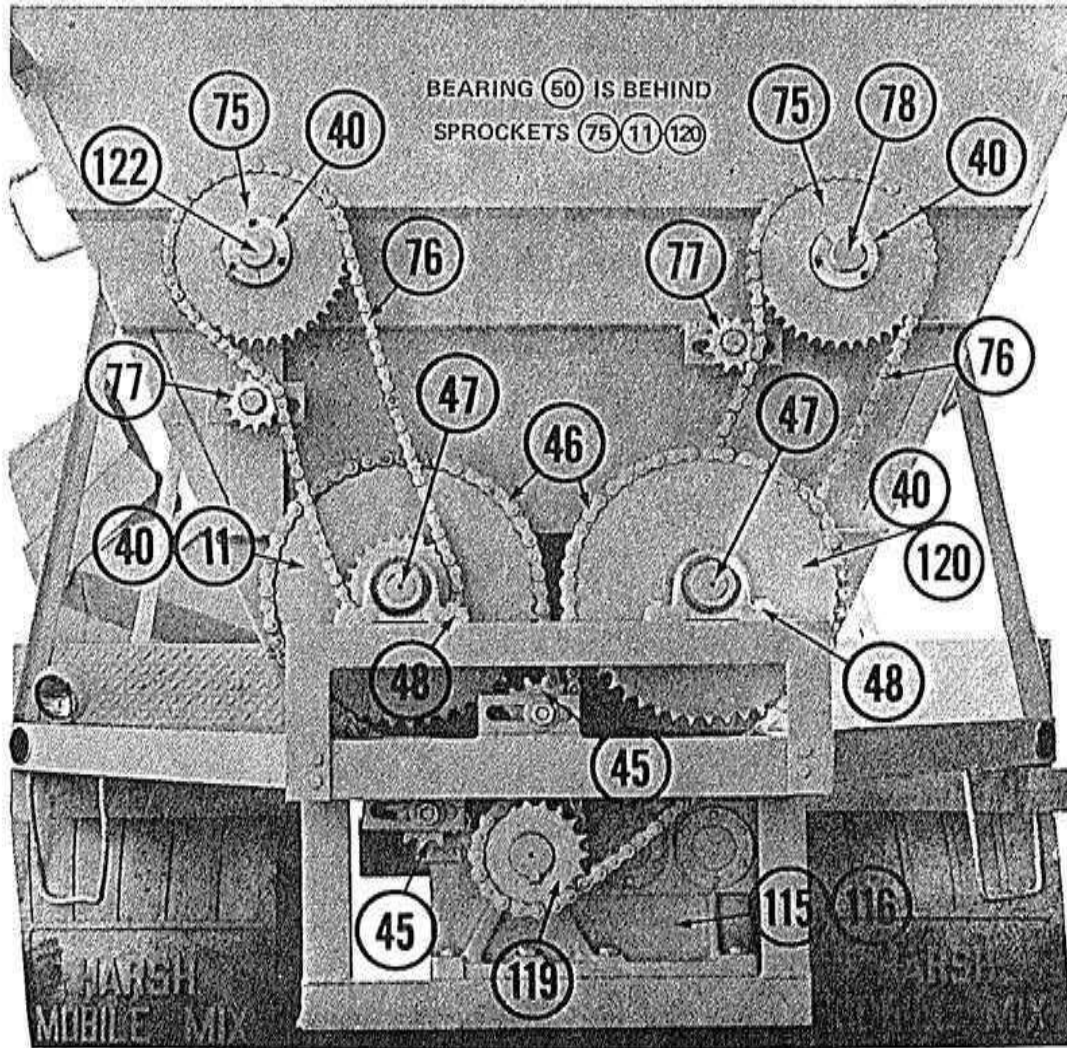

ITEM NO.	PART NO.	DESCRIPTION	NO. REQ'D.			
			300R		350R	
			R	L	R	L
11	100742	Sprocket (HDS 100R 48/80 R24) (LH)	1	1	1	1
40	100078	Sprocket Busing (2-7/16" Dia.)	4	4	4	4
45	A13375	Idler Sprocket (HB 100A 12 x 1")	2	2	2	2
46	10620	Drive Chain (#100 x 96-1/4" Lg.)	2	2	2	2
47	A10652	Flanged Stub Shaft (2-7/16" x 13-3/4" Lg.)	2	2	2	2
48	100050	Pillow Block Bearing (2" Dia.)	2	2	2	2
50	100048	Flanged Bearing (2-7/16" Dia.)	4	4	4	4
75	100073	Sprocket (H80 R40)	2	2	2	2
76	10619	Rear Drive Chain (#80 x 84" Lg.)	2	2	2	2
77	A13374	Idler Sprocket (HB80 A 12 x 1")	2	2	2	2
78	A10653	Flanged Stub Shaft (2-7/16" Dia. x 9-3/4" Lg.)	1	1	1	1
115	100298	Dorris Gear Box (RH) 8324	1	-	1	-
116	100319	Dorris Gear Box (LH) 8324	-	1	-	1
119	100090	Sprocket H100 B19 x 3")	1	1	1	1
120	100074	Sprocket (HDS 100R 48/80 R24) (RH)	1	1	1	1
122	A10624	Flanged Stub Shaft (2-7/16" Dia. x 12" Lg.)	1	1	1	1

FRONT SYSTEM

300M - 350M, 350MS - 400 M, 300R - 350 R

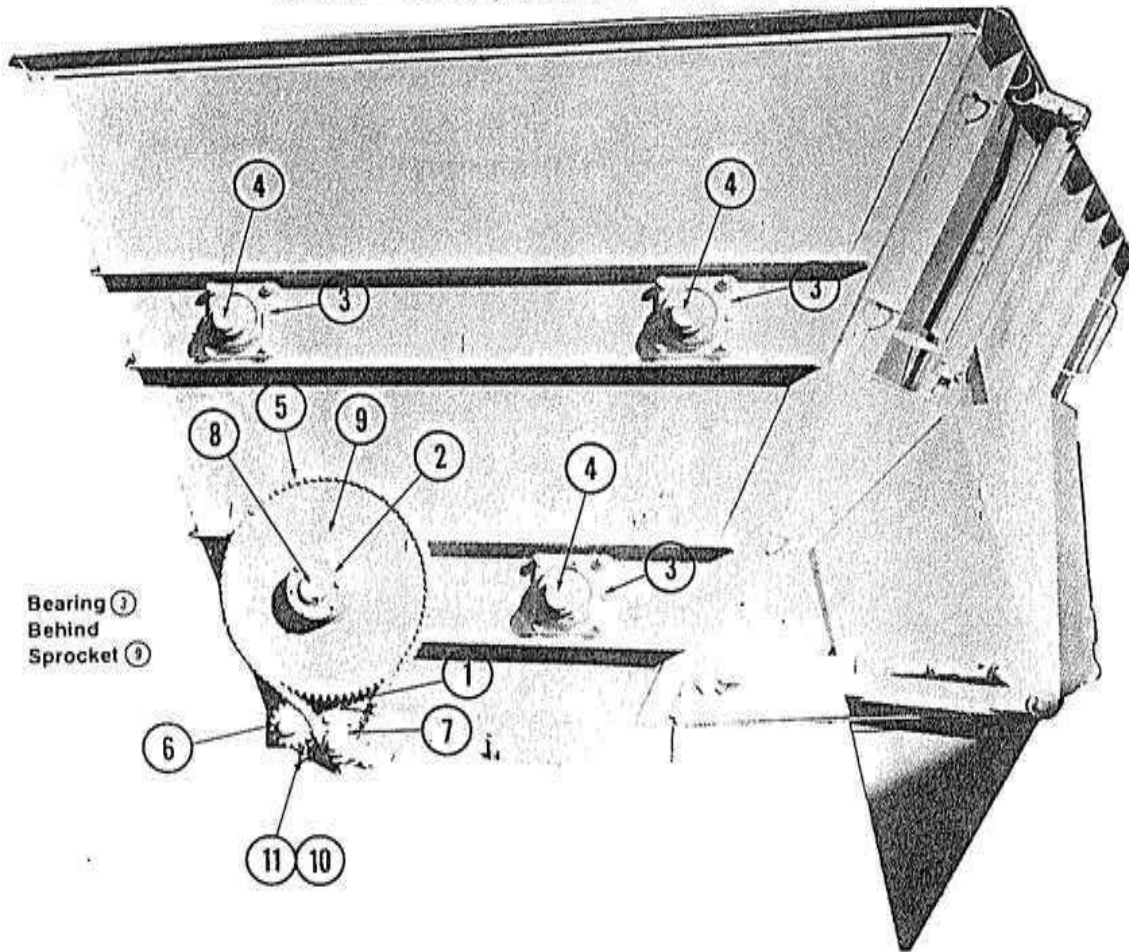

ITEM #	PART #	DESCRIPTION	QTY.
1	100446	Tension spring (1 1/4" Dia x 5 1/2" Lg.)	1
2	100078	Sprocket bushing (2 7/16" Dia.)	1
3	100048	Flanged bearing (2 7/16" Dia.)	4
4	A10710	Flanged stub shaft (2 7/16" Dia. x 6 3/4" lg.)	3
*5	12826	Discharge drive chain (#60 x 66" Lg.) - Dual auger discharge	1
*5	10618	Discharge drive chain (#60 x 57" Lg.) - Single auger discharge	1
6	A13373	Idler sprocket (HB60 A16 x 1")	1
7	100072	Sprocket (H60 B13 x 1 1/4")	1
8	A10653	Flanged stub shaft (2 7/16" Dia. x 9 3/4" Lg.)	1
*9	101213	Sprocket (H60 R80) - Dual auger discharge	1
*9	100088	Sprocket (H60 R60) - Single auger discharge	1
*10	A12489	Idler sprocket mount assy.--Bolt @ center - Dual auger discharge	1
*10	A10210	Idler sprocket mount assy.--Bolt @ end- Single auger discharge	1
11	100334	Shoulder screw (3/8" - 16 UNC) 100334	1
12	10550	Discharge drive shaft (1 1/4 x 16 1/2)	1
13	100053	Flanged bearing (1 1/4)	1
14	10427	Bracket - Idler mount	1
15	100355	Nut, 1"-8 UNC gr. 5	1

400M
FRONT SYSTEM

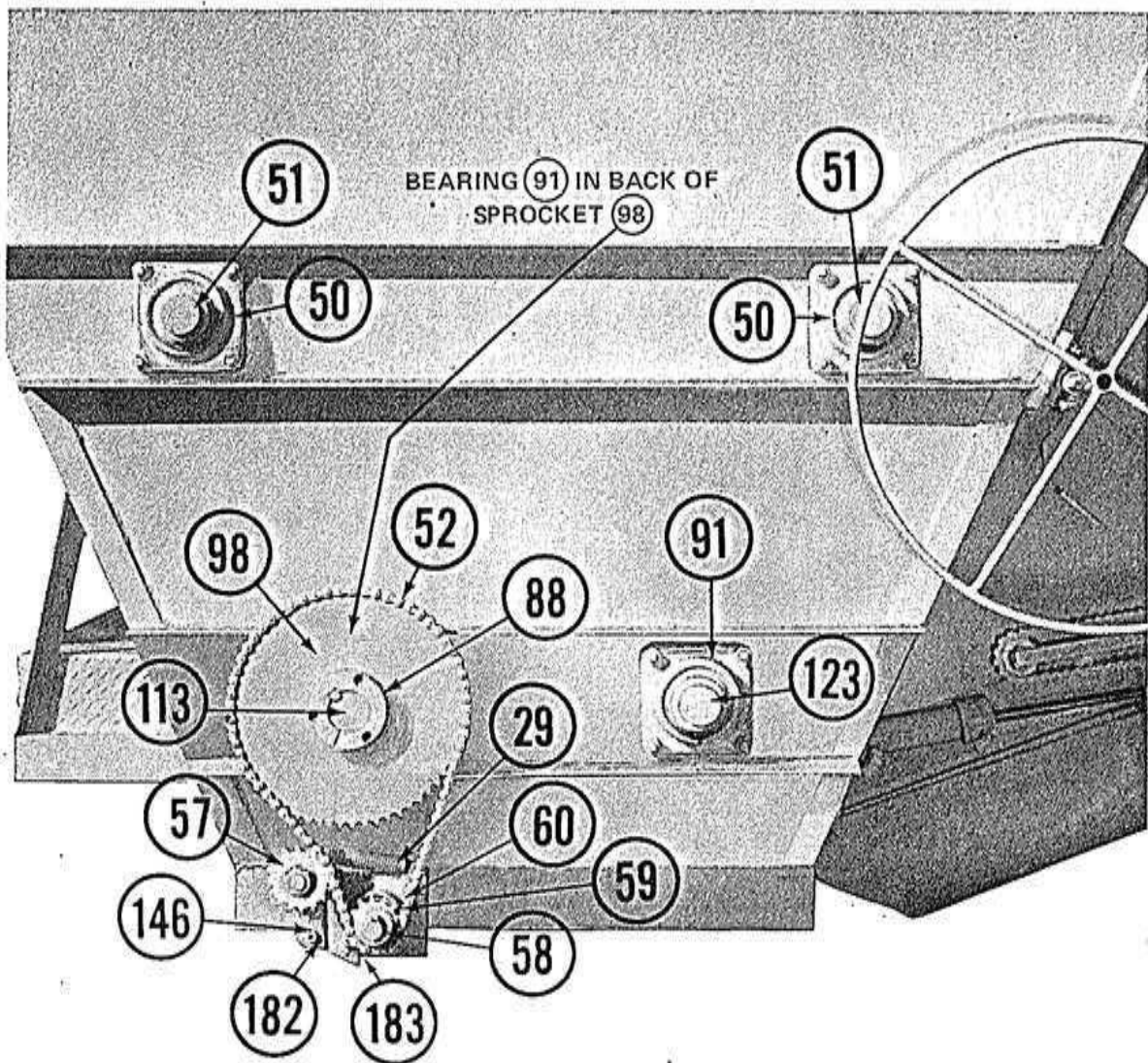

ITEM NO.	PART NO.	DESCRIPTION	NO. REQ'D.
			MODEL 400M
29	100446	Tension Spring (1-1/4" Dia. x 5-1/2" Lg.)	1
50	100048	Flanged Bearing (2-7/16" Dia.)	2
51	10710	Flanged Stub Shaft (2-7/16" Dia. x 6-3/4" Lg.)	2
52	10618	Discharge Drive Chain (#60 x 57" Lg.)	1
57	A13373	Idler Sprocket (HB60 A16 x 1")	1
58	10550	Discharge Drive Shaft (1-1/4" Dia. 16-1/2" Lg.)	1
59	100072	Sprocket (H60 B13 x 1-1/4")	1
60	100053	Flanged Bearing (1-1/4" Dia.)	1
88	100066	Sprocket Bushing (2-15/16" Dia.)	1
91	100067	Flanged Bearing (2-15/16" Dia.)	2
98	100088	Sprocket (H60 R60)	1
113	10812	Flanged Stub Shaft (2-15/16" Dia. x 9-3/4" Lg.)	1
123	10811	Flanged Stub Shaft (2-15/16" Dia. x 7" Lg.)	1
146	10210	Mount Assembly - Idler Sprocket	1
182	100334	Shoulder Screw 3/8 - 16 UNC	1
183	10427	Bracket - Idler Mount Ass'y.	1

300T & 350T
FRONT SYSTEM

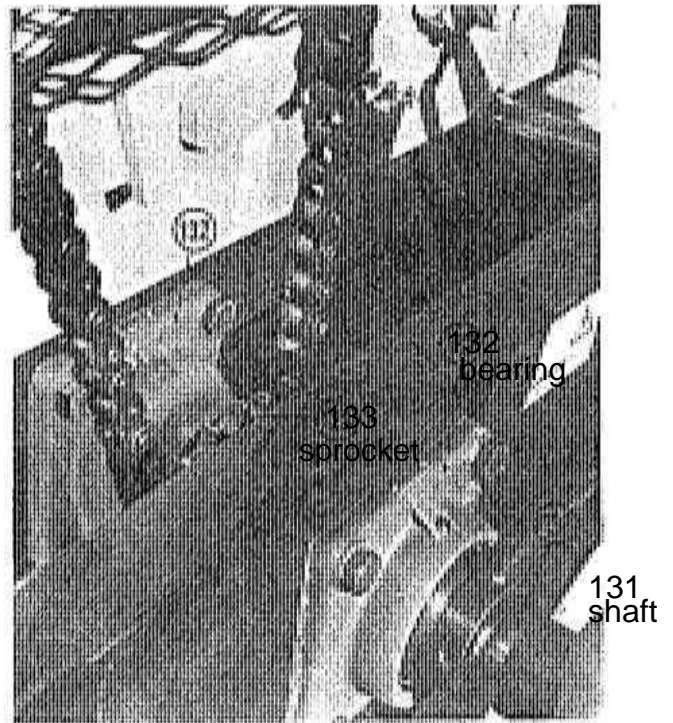
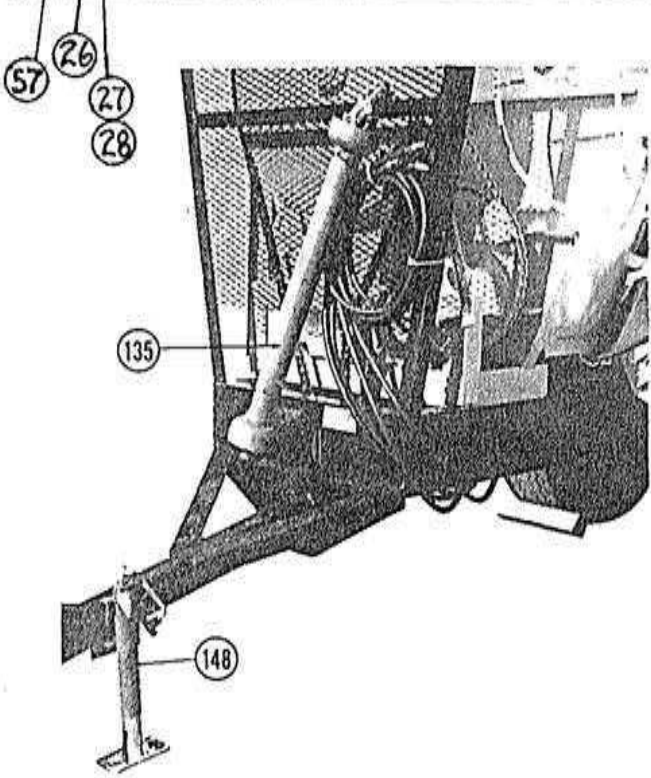
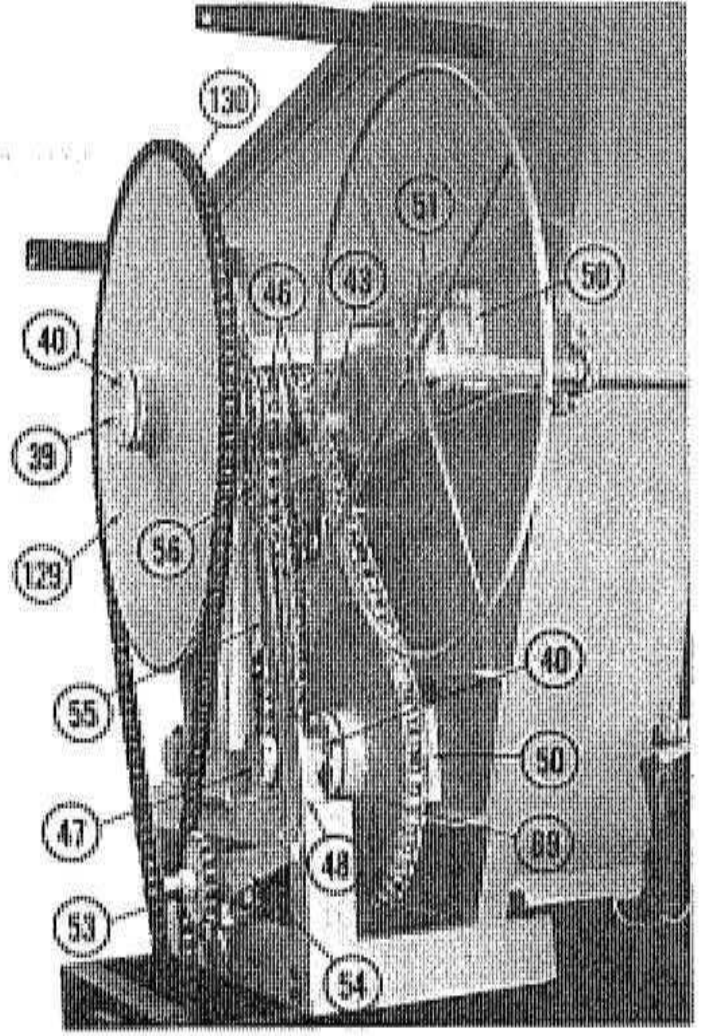
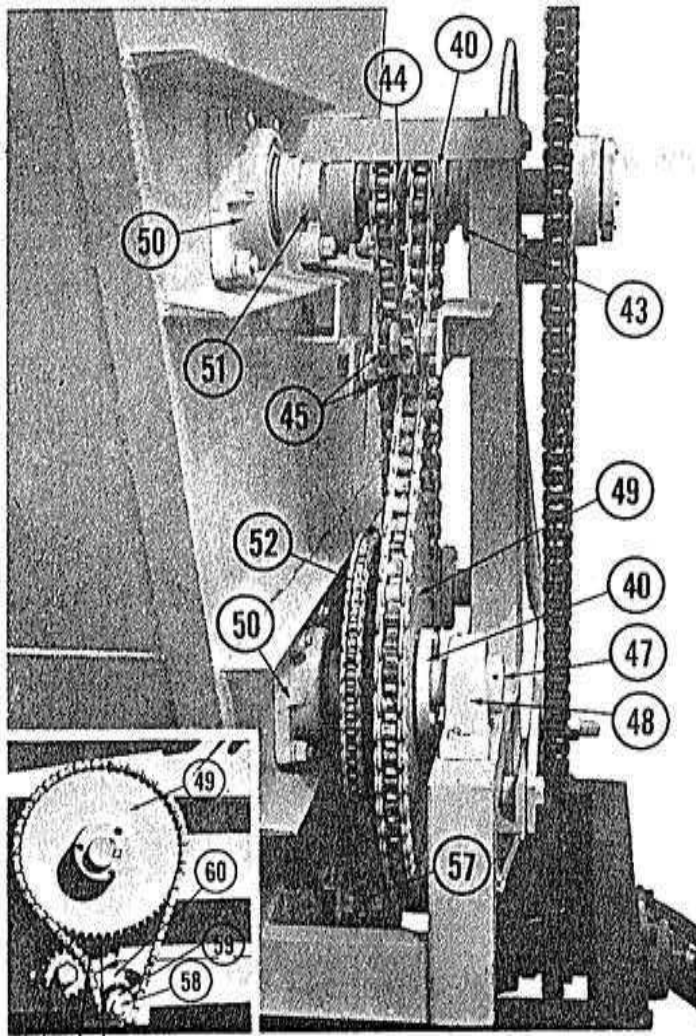

FIGURE 2

FIGURE 1

FRONT SYSTEM 300T - 350T

ITEM	PART	DESCRIPTION	NUMBER REQ'D	
			300T	350T
39	10548	Top shaft (2 7/16" Dia. x 16" Lg.)	1	1
40	100078	Sprocket bushing (2 7/16" Dia.)	4	4
43	100051	Flanged bearing (2 7/16" Dia.)	2	2
44	100076	Sprocket (DS 100 R17)	1	1
45	A13375	Idler sprocket (HB100 A12 x 1")	2	2
46	10620	Drive chain (#100 x 96 1/4")	2	2
47	A10652	Flanged stub shaft	2	2
48	100050	Pillow block bearing (2" Dia.)	2	2
*49	101212	Sprocket (DS 100 R48/60 R80)Dual auger disch.	1	1
*49	100083	Sprocket (DS 100 R48/60 R60)Single auger disch.	1	1
50	100048	Flanged bearing (2 7/16" Dia.)	4	4
51	A10710	Flanged stub shaft (2 7/16" Dia. x 6 3/4" Lg.)	2	2
*52	12826	Discharge drive chain (#60x66")Dual auger disch.	1	1
*52	10618	Discharge drive chain (#60 x 60")Single aug disch	1	1
53	A13376	Idler sprocket (HB80 A18 x 1")	1	1
54	A10209	Chain tightener assy.	1	1
55	100447	Tension springs (1 1/4" Dia. x 11 3/4" Lg.)	1	1
56	10820	Tightener chain	1	1
57	A13373	Idler sprocket (HB60 A16 x 1")	1	1
58	10550	Shaft, 1 1/4 x 16"	1	1
59	100072	Sprocket (H60 B13 x 1 1/4")	1	1
89	100103	Sprocket (H100 R48)	1	1
129	A15140	Sprocket (H80 R112)	1	1
130	11383	Main drive chain (#80 x 157" Lg.)	1	1
131	10765	Lower middle shaft (2" Dia. x 14" Lg.)	1	1
132	100056	Bearing, flanged (2" Dia.)	2	2
133	100069	Sprocket (H80 B14 x 2")	1	1
135	100714	Telescopic drive shaft	1	1
26	100446	Spring 1 1/8" Dia. x 5 1/2" Lg.)	1	1
*27	A12489	Idler sprocket mount assy. Bolt @ center(DAD)	1	1
*27	A10210	Idler sprocket mount assy. Bolt @ end (SAD)	1	1
28	100334	Shoulder screw 3/8" - 16 UNC	1	1
148	100652	Jack with retainer	1	1
30	10550	Shaft, discharge drive (1 1/4x16 1/2)	1	1
31	100053	Flanged bearing 1 1/4	1	1
32	4332	Yoke 1 1/4 weasler (end of 10765)	1	1

REAR SYSTEM 300T - 350T

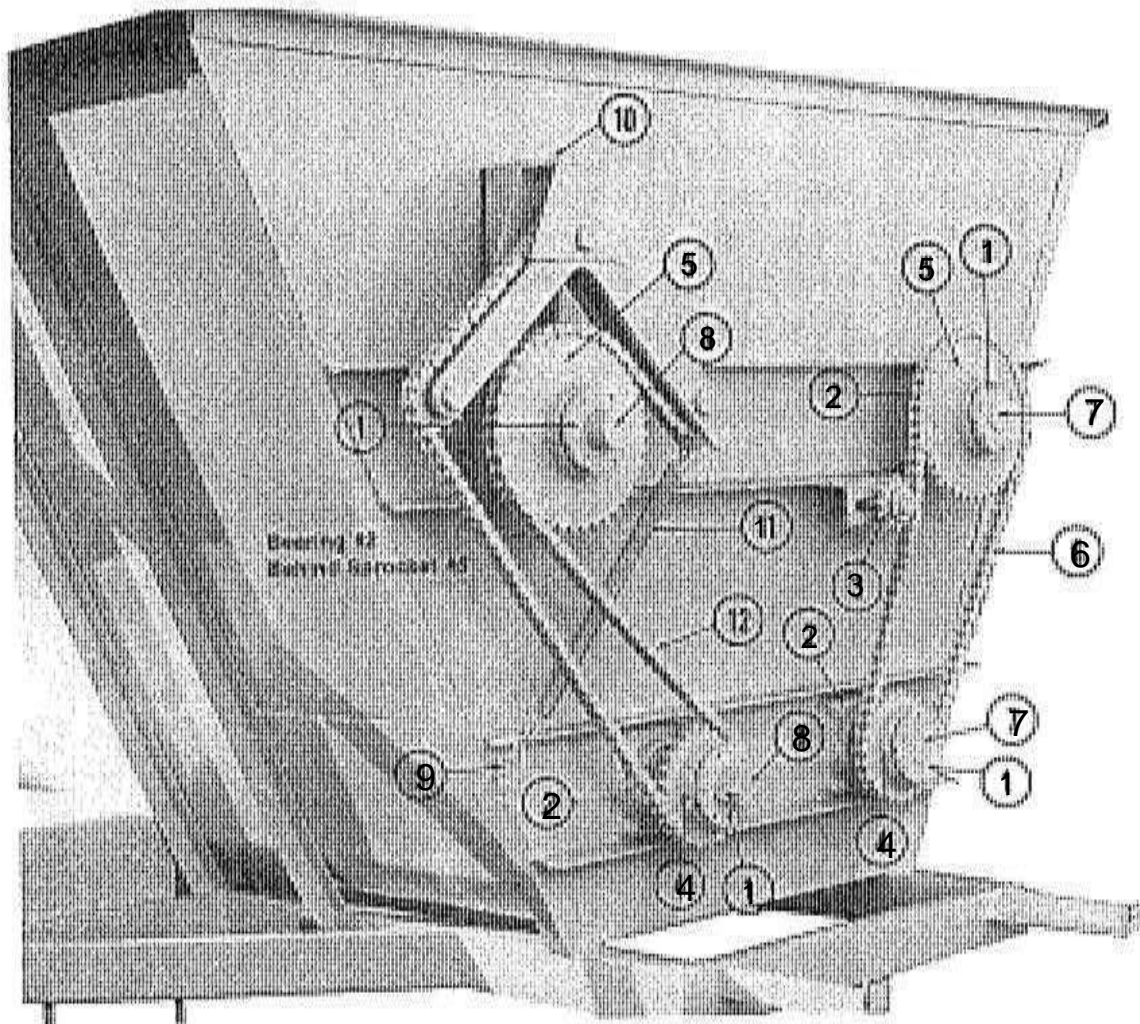

ITEM NUMBER	PART NUMBER	DESCRIPTION	NUMBER REQUIRED			
			MODEL 350T		MODEL 300T	
			W/REV	W/OUT REV.	W/REV	W/OUT REV.
1	100078	Sprocket bushing (2 7/16" Dia.)	4	4	4	4
2	100048	Flanged bearing (2 7/16" Dia.)	4	4	4	4
3	A13374	Idler sprocket (HB80 A12 x 1")	1	-	1*	-
*3	A13376	Idler sprocket (HB80 A 18 x 1")	-	2	-	2
4	100120	Sprocket (H80 R24)	2	2	2	2
5	100073	Sprocket (H80 R40)	2	2	2	2
6	10619	Chain rear drive (#80 x 84" Lg.)	1	2	1	2
7	A10653	Flanged stub shaft (2 7/16" Dia. x 9 3/4" Lg.)	2	4	2	4
8	A10624	Flanged stub shaft (2 7/16" Dia. x 12" Lg.)	2	-	2	-
9	12495	Tightener chain	1	-	1	-
10	A12713	Auger reversing assy.	1*	-	1*	-
11	100447	Spring (1 1/4" Dia. x 11 3/4" Lg.)	1	-	1	-
12	12493	Chain rear drive (#80 x 135" Lg.)	1	-	1	-
	A13376	80 A18 x 1"	-	2	-	2

* 3 Sprockets included with item 10 Auger Reversing Assy.

FRONT SYSTEM 300ST - 350ST

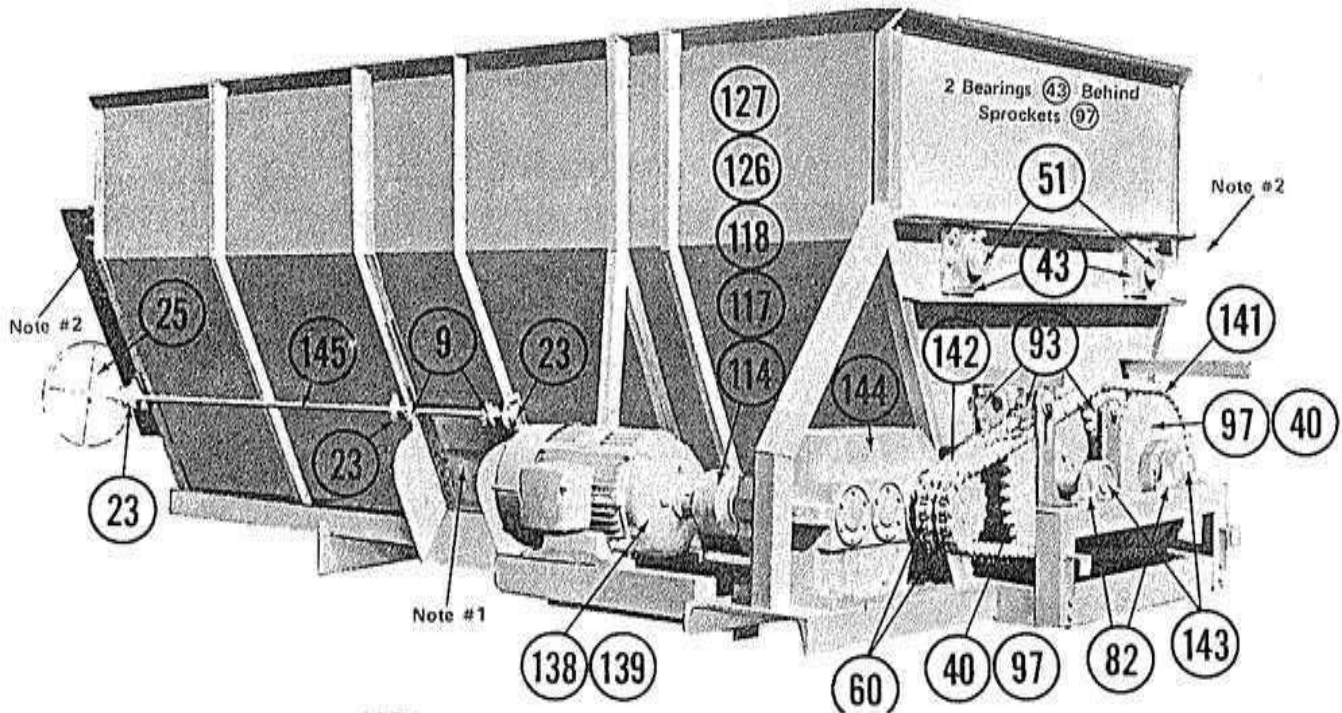

NOTE:

1. Discharge location is per each individual's specification.
2. Shielding made to fit each unit's requirement.

ITEM NO.	PART NO.	DESCRIPTION	NO. REQ'D	
			30 H.P.	40 H.P.
50	100048	Bearing, flanged (2 7/16" Dia.)	2	2
9	100092	Sprocket (60 B13 x 1")	2	2
23	100058	Bearing, pillow block (1" Dia.)	3	3
***145		Discharge door shaft (1" Dia.)	1	1
25	10673	Wheel assembly - Discharge door	1	1
40	100078	Sprocket bushing (2 7/16" Dia.)	2	2
82	100059	Bearing, pillow block (2" Dia.)	2	2
43	100051	Bearing, flanged (2 7/16" Dia.)	2	2
51	A10710	Flanged stub shaft (2 7/16" Dia. x 6 3/4" Lg.)	2	2
60	100063	Sprocket (H120 B16 x 3")	2	2
93	A13377	Idler sprocket (H120 A12 x 1")	3	3
97	100087	Sprocket (H120 R40)	2	2
138	100737	30 H.P. Electric motor	1	-
139	100738	40 H.P. Electric motor	-	1
141	11402	Main drive chain (#120 x 127" Lg.)	1	1
142	11403	Main drive chain (#120 x 88" Lg.)	1	1
143	A10750	Flanged stub shaft (2 7/16" Dia. x 15 1/2" Lg.)	2	2
144	100425	Dorris 8340X Gear box	1	1
*114	4036	Inserts (Browning Coupling FS7)	1	1
*117	4214	Half coupling (Browning CHFS7QX)	2	2
118	4238	Bushing, 1 7/8" Dia. (Browning Q1)	1	-
126	4239	Bushing, 1 1/4" Dia. (Browning Q1)	1	1
127	4240	Bushing, 2 1/8" Dia. (Browning Q1)	-	1

* Alternate for Items 114 and 117.

**128	4241	Coupling (Browning CHCFR9Q)	2	2
-------	------	-----------------------------	---	---

** Alternate for Item 128.

136	4242	Coupling (Browning CHCFR10Q)	2	2
-----	------	------------------------------	---	---

*** Shaft length controlled by Door location.

REAR SYSTEM 300ST - 350ST

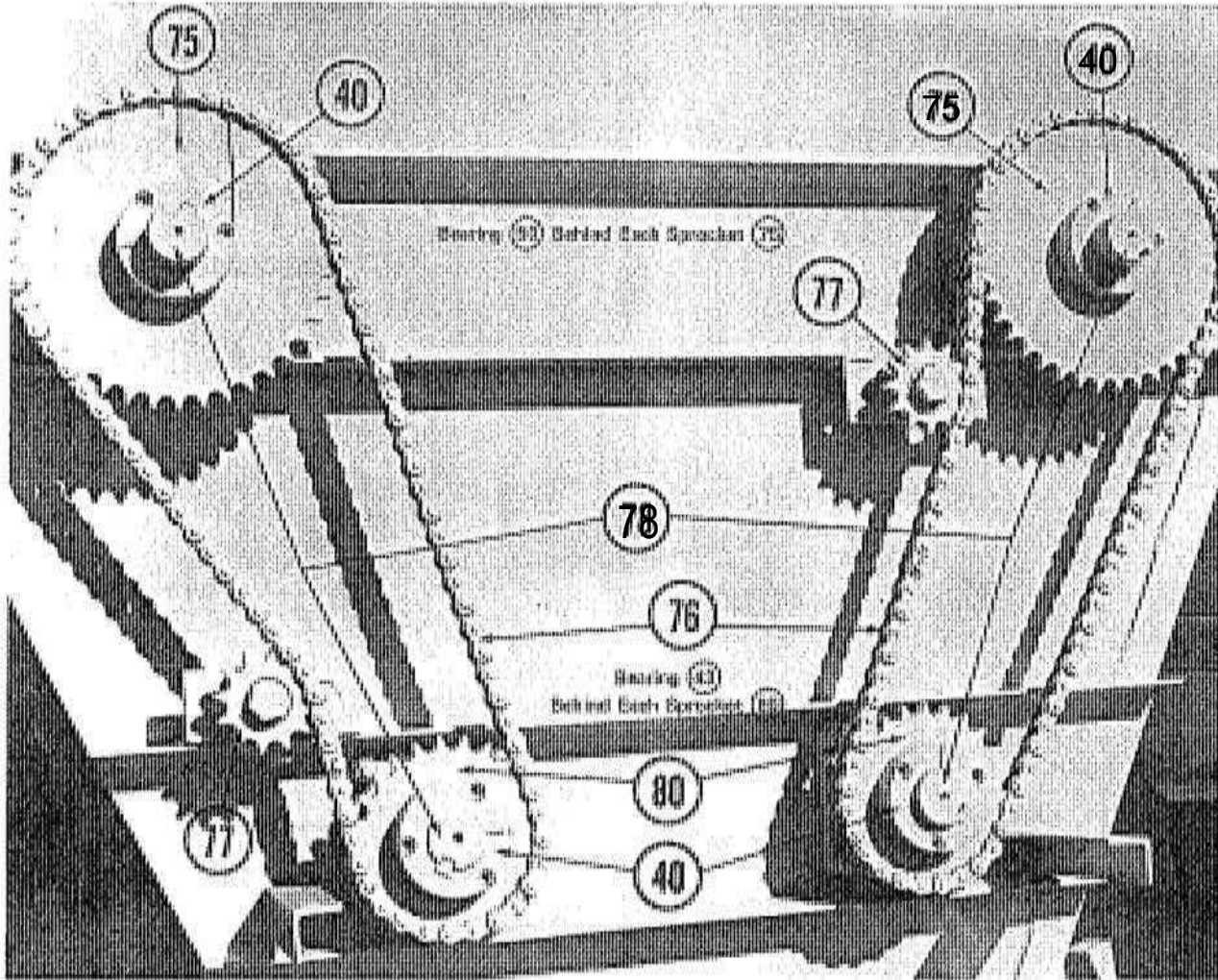

ITEM NO.	PART NO.	DESCRIPTION	NO. REQ'D	
			MODEL	MODEL
			300ST	350ST
40	100078	Sprocket bushing (2 7/16" Dia.)	4	4
43	100051	Bearing, flanged (2 7/16" Dia.)	2	2
50	100048	Bearing, flanged (2 7/16" Dia.)	2	2
77	A13374	Idler sprocket (HB80 A 12 x 1")	2	2
80	100121	Sprocket (H80 R32)	2	2
75	100073	Sprocket (H80 R40)	2	2
76	10619	Rear drive chain (#80 x 84" Lg.)	2	2
78	A10653	Flanged stub shaft (2 7/16" Dia. x 9 3/4" Lg.)	4	4

SHIELD SYSTEM

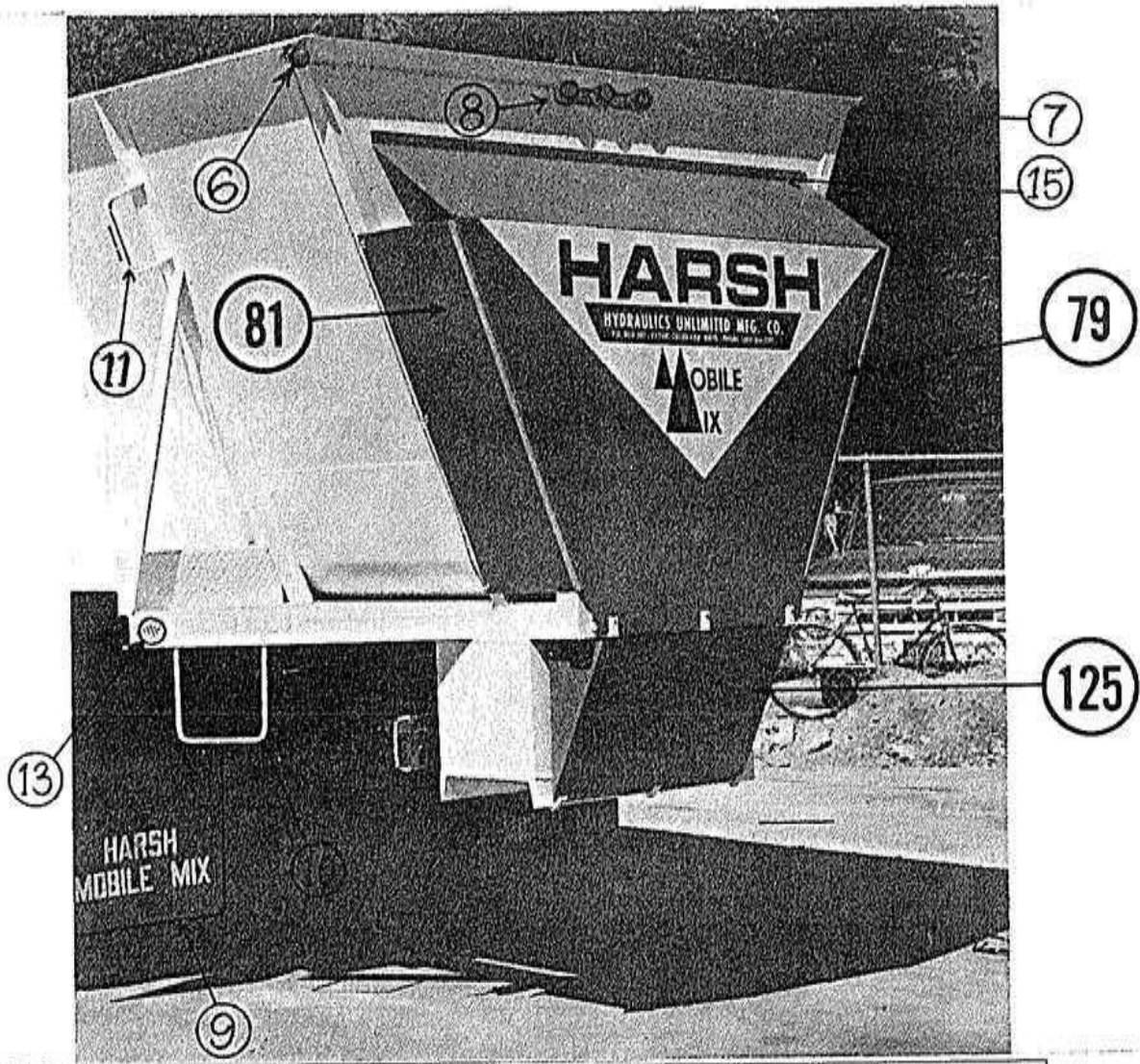

ITEM NUMBER	PART NUMBER	DESCRIPTION	NO. REQ'D	
			MODEL 300R	MODEL 350R
79	10198	Shield, main	1	1
*81	10915	Door side (13 1/2" x 42 1/2" Lg.)	2	2
*125	10199	Shield, lower - angled as shown	1	1
*125	14901	Shield, lower - squared not shown	1	1
*81	12484	Door side (24" x 42 1/2" Lg.)	2	2
5	100399	Hinge	2	2
6	100310	Light amber	1	1
7	100311	Light red	1	1
8	100335	Clearance light 3 lamp red	1	1
9	100312	Mud flap (Harsh)	2	2
10	10591	Step	1	1
11	10590	Hand hold	1	1
12	102439	Bunk light	1	1
13	100308	Reflector amber	2	2
14	100309	Reflector red	2	2
15	12485	Extension	1	1

OIL BATH

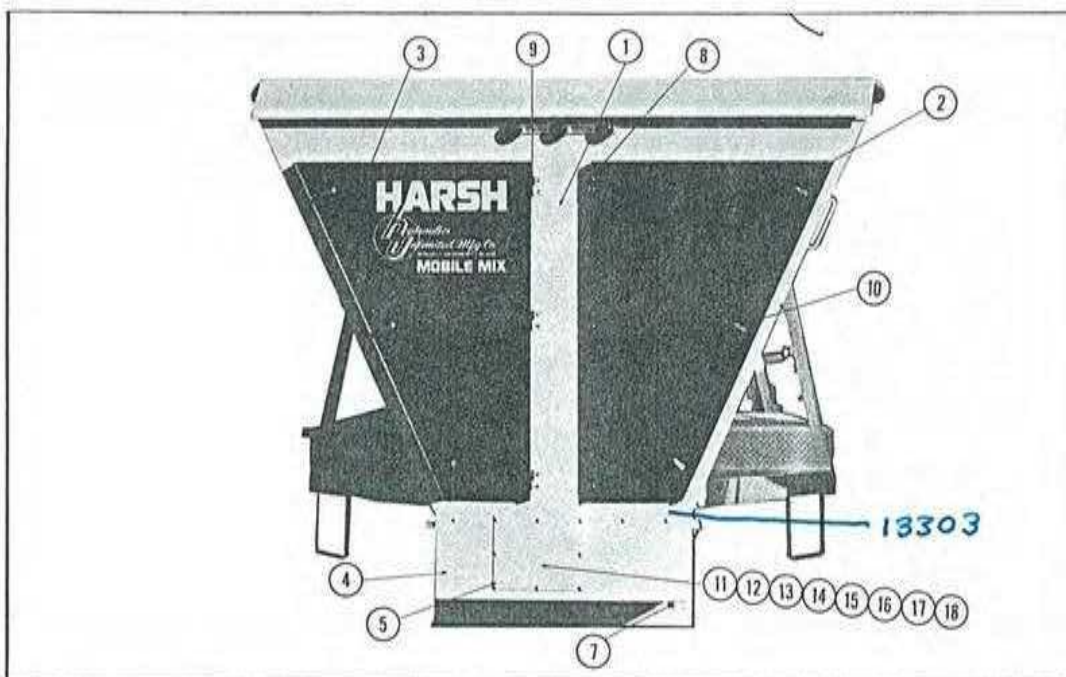

ITEM NUMBER	PART NUMBER	DESCRIPTION	NO. REQ'D	
			540 RPM	1,000 RPM
1	13304	Center panel	1	1
	13313	Door (right)	1	1
3	13311	Door (left)	1	1
4	A13465	Reservoir assy.	1	-
4	A13384	Reservoir assy.	-	1
5	13436	Inspection plate	1	1
6	100495	Drain (1" NPT coupling half)	1	1
7	100358	Plug (1" NPT)	1	1
8	101363	Hinge (right)	3	3
9	101364	Hinge (left)	3	3
10	101305	Latch	6	6
11	A13515	Retainer assy.	-	1
12	A13518	Sleeve assy.	-	1
13	A13521	Collar assy.	-	1
14	100163	O-Ring 4 1/2 OD x 3/16 CS	-	1
15	A13458	Rear retainer collar assy.	1	-
16	A13460	Front retainer collar assy.	1	-
17	101385	Retaining ring (3000-X275)	1	-
18	101384	Poly pack seal (2 3/4" OD x 2" ID x 3/4 CS)	-	-

13303 DOOR BTM FILLER

SHIELD SYSTEM

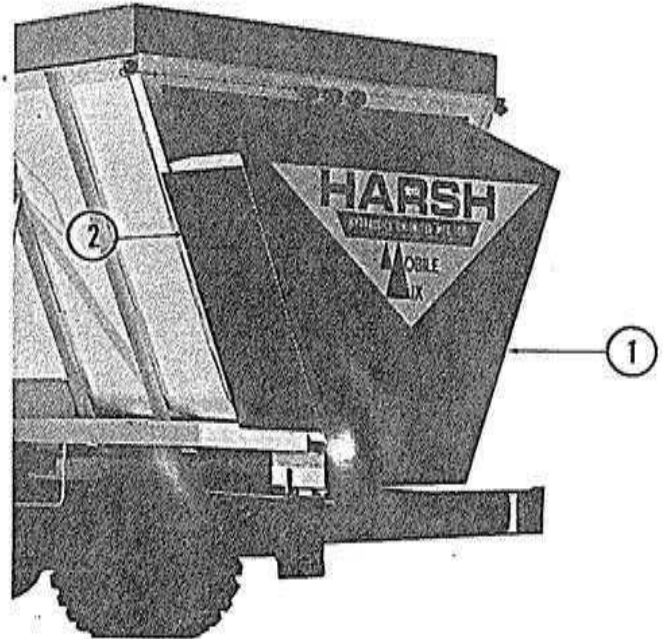
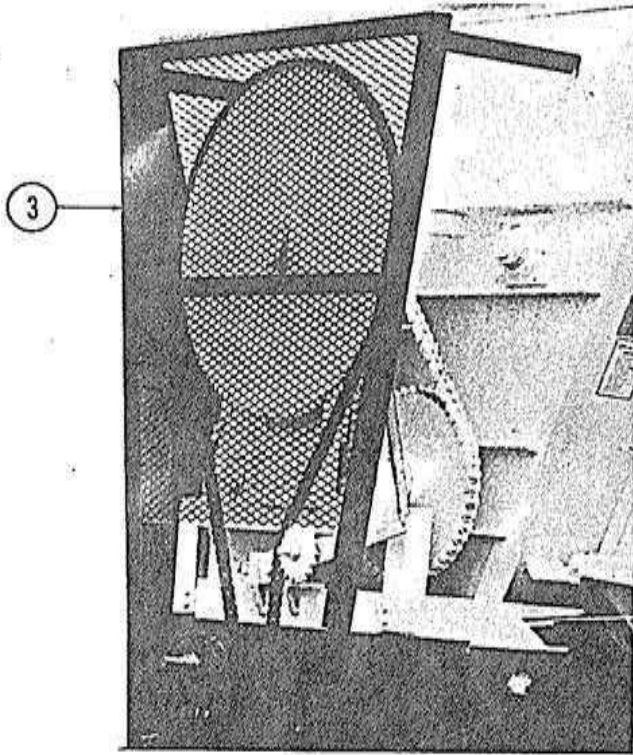

ITEM NUMBER	PART NUMBER	DESCRIPTION	NUMBER REQ'D.	
			MODEL 300T	MODEL 350T
1	10198	Shield, Upper	1	1
2	10915	Door, Side	2	2
3	10846	Shield, Front	1	1

PARTS LIST TRAILER

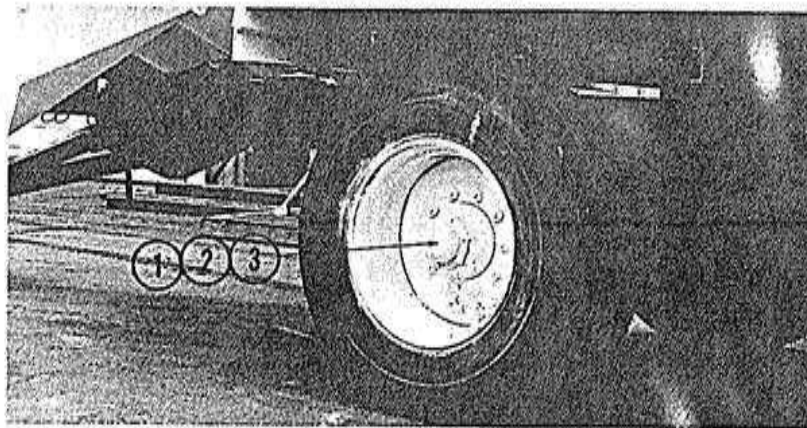

DWG. NO.	PART NO.	DESCRIPTION	NO. REQ'D.
1	100666	Tire 16.5 x 22.5 (Min. 14 ply)	2
2	100665	Wheel 22.5 x 15 (10 Hole Bud)	2
3	101113	Axle (10 Bud)	1

HYDRAULICS PARTS LIST

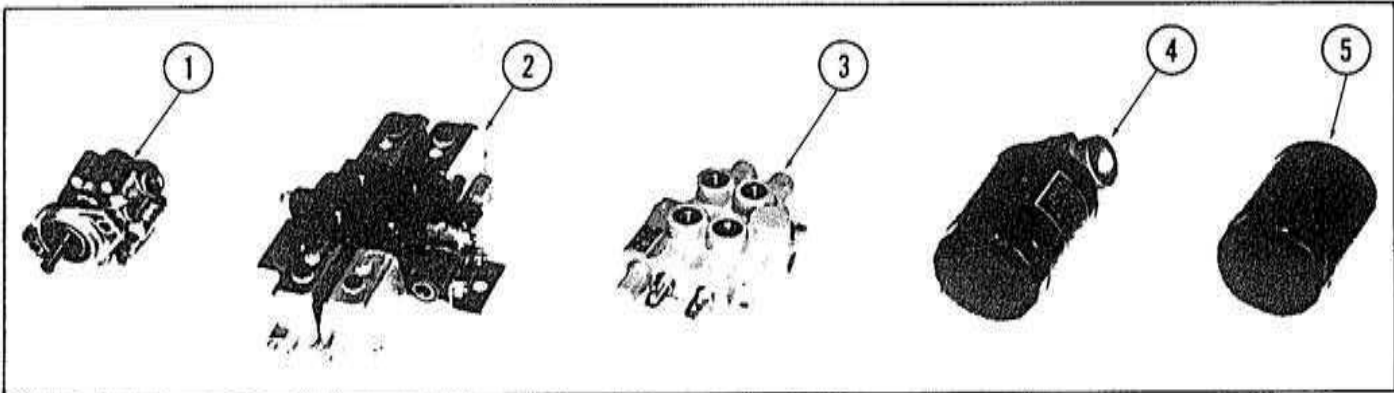

ITEM NUMBER	PART NUMBER	DESCRIPTION	NO. REQ'D	
			MANUAL CONTROLS	ELECTRICAL CONTROLS
1	100916	Pulley	1	1
1	100929	Pump	1	1
2	101240	Valve, electrical	1	-
3	101247	Valve, manual control	-	1
4	101242	Filter with element & bracket	1	1
5	4310	Filter element	*	*
6	4406	Seal kit (for 101242)	*	*
7	4410	Coil (for 101242)	*	*
8	4461	Seal (for 100929)	*	*

* Replacement part only.

A11894	Reservoir (3 qt.)
100182	Breather cap
101251	Elbow, 3/8" M tube x 1/2 ST O-Ring
101210	Elbow, 1/2" NPT M x 1/2" NPT M
101244	Elbow, 3/8" NPT M x No. 6 Vic M tube
101241	Elbow, long nex No. 6 ST O-Ring x No. 6 Vic M tube
101642	Elbow, 90° - No. 6 SAE
101644	Adapter No. 6 SAE to No. 6 Vic
101324	Toggle switch
A9441	Mounting bracket for 100929
101597	Elbow, str. #10 SAE x 1/2 NPT female
101785	Elbow, str. 7/8 #10 SAE

TRUCK MAIN DRIVE SYSTEM

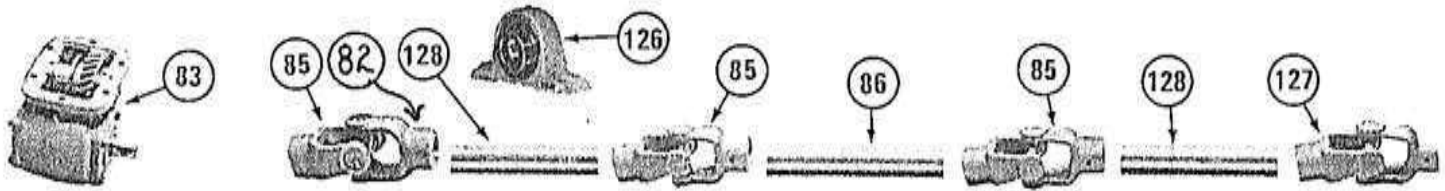

ITEM NUMBER	PART NUMBER	DESCRIPTION	NO. REQ'D
			MODEL 400M
83	**	P.T.O.	1
126	100055	1 1/4" Pillow block bearing	4 Min.
**85	100492	U-Joint, 1 1/4" Rnd. to 1 1/4" Rnd.	3
*127	100489	U-Joint, 1 1/4" Rnd. to 1 3/8" Rnd.	1
**128	10623	1 1/4" Rnd. drive shaft, long	2
86	10629	1 1/4" Rnd. drive shaft, short	1
82	100242	Screw SQ set 3/8 x 5/8	
	100662	Cross	
	100659	1 1/4" Rnd. yoke	

** Ordered by OLD P.T.O Number or Transmission Number

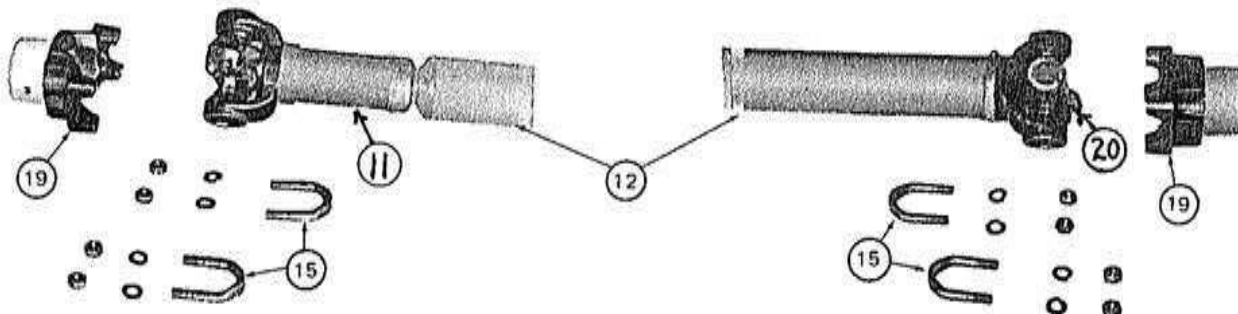

11	100881	Yoke sleeve	
12	100084	Drive shaft (cut to length)	1
15	100882	U-Bolts for bolt-on yoke	4
19	100598	Yoke - 1 1/4" Dia. - bolt-on	2
20	100785	Cross	

• Alternate for item 85 (1 req'd.); item 128 (1 req'd.); and item 127 (1 req'd.)

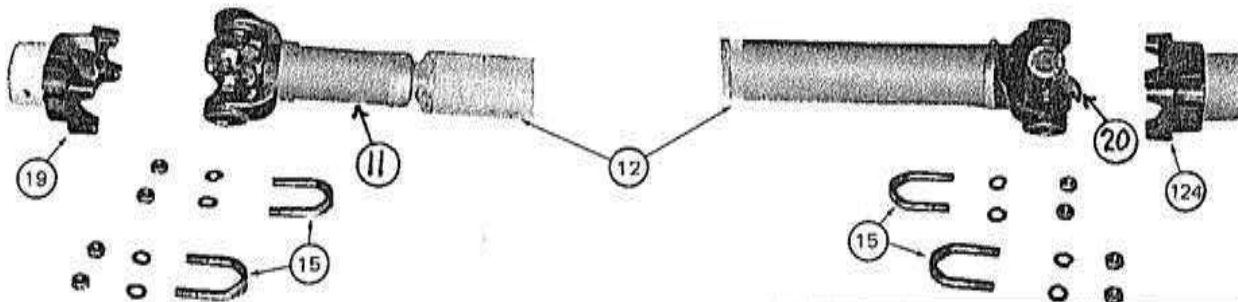

11	100881	Yoke sleeve	
12	100884	Drive shaft (Cut to Length)	1
15	100882	U-Bolt for bolt-on yoke	4
19	100598	Yoke - 1 1/4" Dia. - bolt-on	1
*124	100724	Yoke - 1 3/8" Dia. - bolt-on	1
20	100785	Cross	

* Alternate for item 124

121	100880	Yoke - electric clutch - press-on	1
-----	--------	-----------------------------------	---

TRAILER & DRIVE LINE ASSEMBLY FOR MODELS 302T & 354T

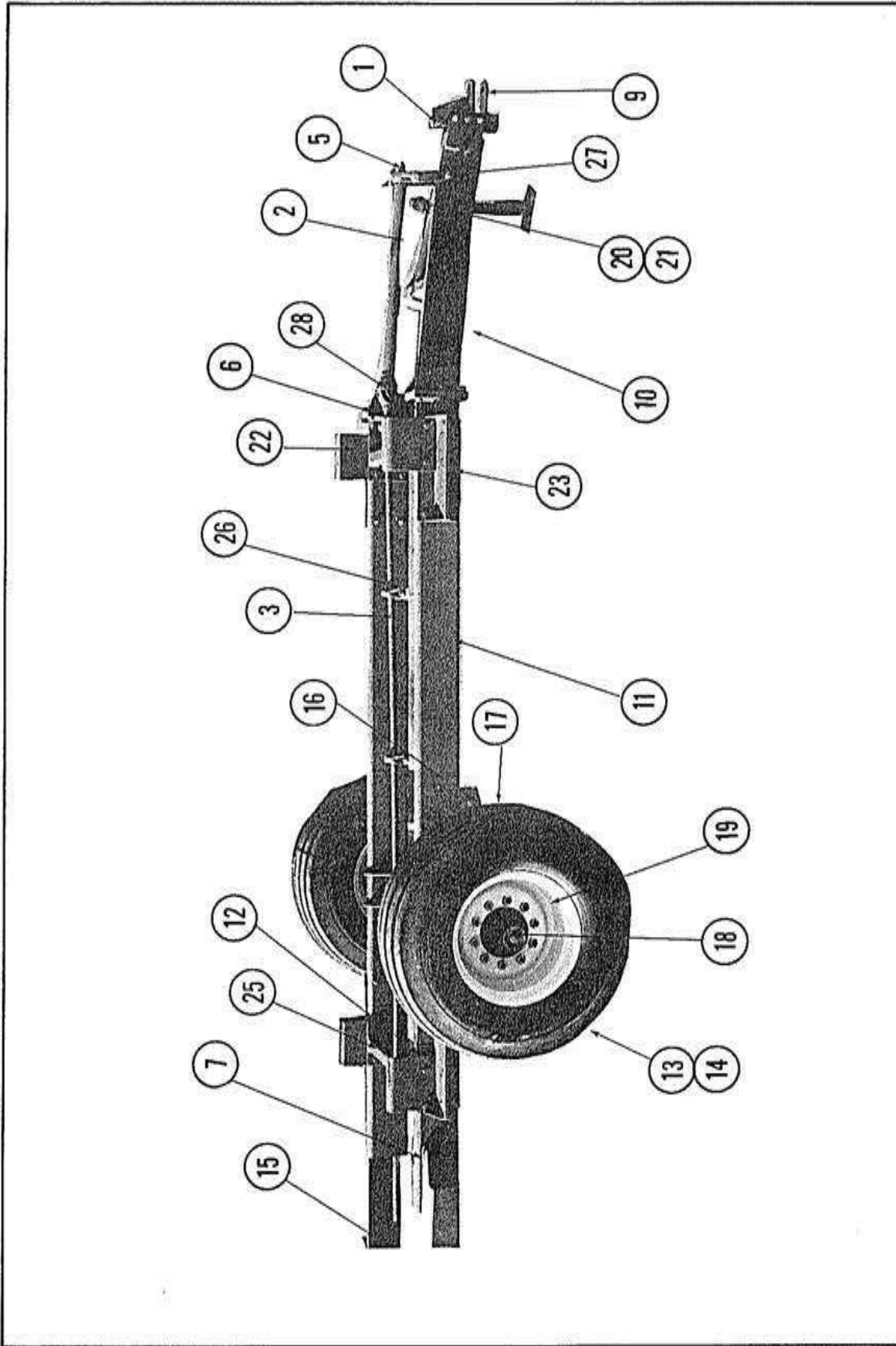

H.U. PART NO. 101547
REV. 5-83

**TRAILER AND DRIVE LINE ASS'Y
FOR MODELS 302T AND 354T**

ITEM NUMBER	PART NUMBER	DESCRIPTION	QTY. REQ'D	
			302T	354T
1	101433	Telescopic drive shaft (D-9961)	1	1
2	101432	Tubular drive shaft (D-9960)	1	1
3	13474	Drive line shaft	1	-
3	13475	Drive line shaft	-	1
4	A13721	Bearing mount bracket assy.	1	1
5	101435	Bearing (VAK 1 3/8)	1	1
6	100055	Bearing (RAK 1 ¼)	6	6
7	100884	Drive shaft assy. (9553-5F)	1	1
8	13511	Shield - not shown	1	1
9	A13001	Clevis assy.	1	1
10	A13275	Tongue assy.	1	1
11	A13504	Frame tube assy.	2	-
11	A13288	Frame tube assy.	-	2
12	A13284	Frame crossmemeber assy.	2	2
13	A12401	Block assy., axle mount.	2	2
14	A12398	Axle mounting assy.	2	2
15	A7293	Bumper assy.	1	1
17	A12414	Radius rod, adjustable	2	2
18	101113	Axle w/ lug nuts	1	1
19	100665	Wheel	2	2
20	12849	Jack mounting plate	1	1
21	100652	Jack	1	1
22	A13549	Scale bracket assy. (Left)	2	2
23	A13550	Scale bracket assy. (Right)	2	2
24	A13294	Bracket	4	4
25	A11879	Stabilizer bar	4	4
26	13331	Bearing supportangle	1	1
27	13470	Bearing mount bracket	3	3
28	13471	Bearing support angle (Front)	1	1
TELESCOPIC AND TUBULAR DRIVE LINE BREAK DOWN (WEASLER)			101433	101432
	4331	Bearing nylon 4N21	1	1
	4332	Yoke, D5	0	1
	4333	Yoke, splined 1000 RPM	1	0
	4334	Yoke, splined 540 RPM	1	0
	4335	Centralizer, nylon	1	1
	4336	Bearing nylon 4N20	1	1
	4337	Repair kit (1000 RPM Yoke)		
	4338	Repair kit (540 RPM Yoke)		

TRAILER & DRIVE LINE ASSEMBLY FOR MODEL 406T

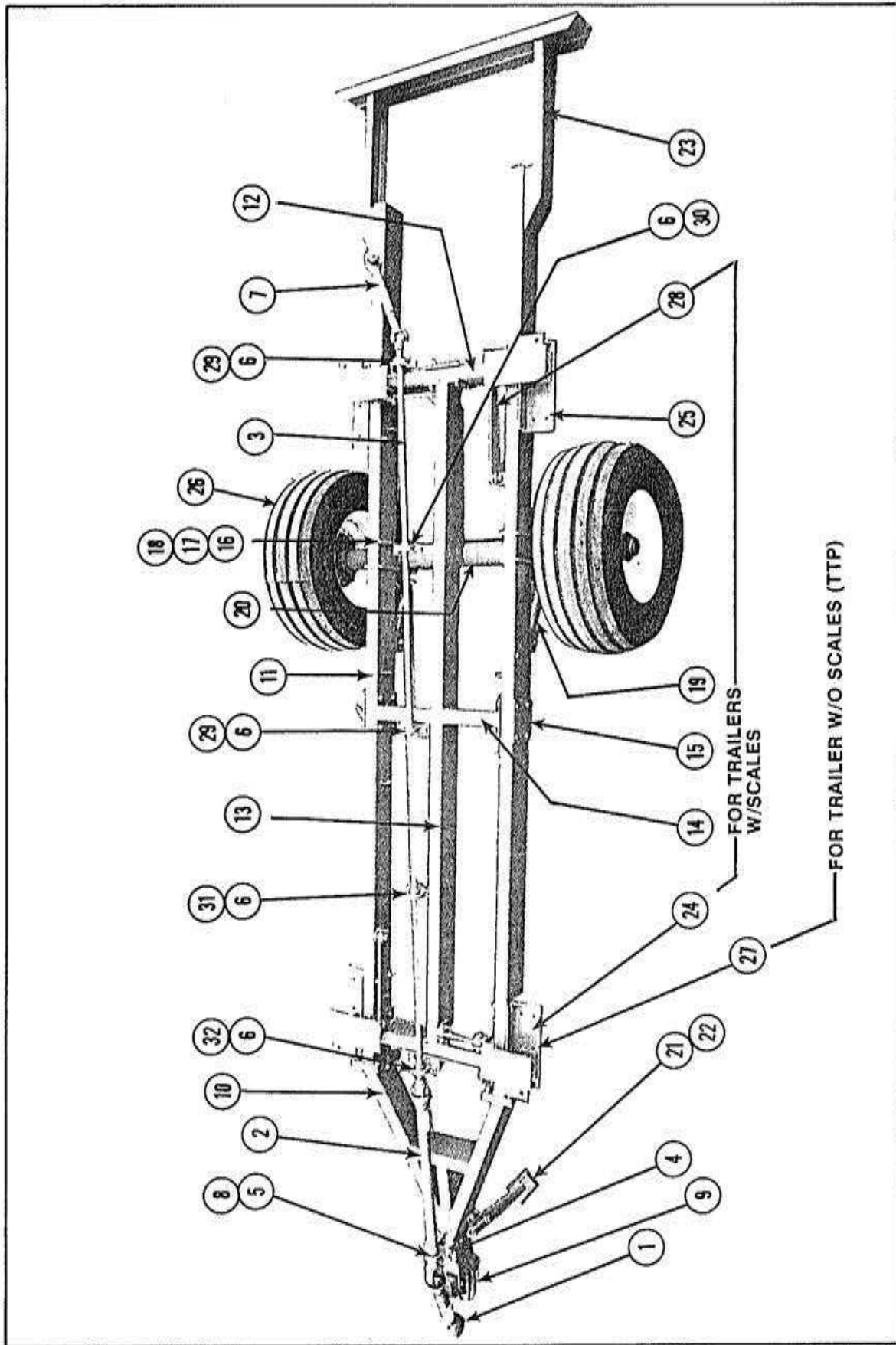

**TRAILER & DRIVE LINE ASSEMBLY
FOR MODEL 406T**

ITEM NUMBER	PART NUMBER	DESCRIPTION	QTY. REQ'D
1	101433	Telescopic drive shaft	1
2	101432	Tubular drive shaft	1
3	13476	Drive line shaft	1
4	A13721	Bearing mount bracket assy.	1
5	101435	Bearing (VAK 1 3/8)	1
6	100055	Bearing (RAK 1 1/4)	5
7	100884	Drive shaft assy. (9553-SF)	1
8	13511	Shield - not shown	1
9	A13001	Clevis assy.	1
10	A13275	Tongue assy.	1
11	A13422	Frame Tube assy.	2
12	A13424	Frame crossmember assy.	2
13	A13426	Center tube assy.	1
14	A13429	Half crossmember assy.	2
15	13826	Plate	4
16	A12398	Axle mounting assy.	2
17	101357	U-Bolt w/ nuts	4
18	A12401	Block assy., axle mount	2
19	A12414	Radius rod, adjustable	2
20	101113	Axle w/ lug nuts	1
21	12849	Jack mounting plate	1
22	100652	Jack	1
23	A7293	Bumper assy.	1
24	A13549	Scale bracket assy. (Left)	2
25	A13550	Scale bracket assy. (Right)	2
26	100665	Wheel	2
27	A13294	Bracket	4
28	A11879	Stabilizer bar	4
29	13331	Bearing support angle	2
30	13314	Bearing mount bracket	1
31	13472	Bearing support bracket	1
32	13478	Front bearing bracket	1

			101433	101432
	4331	Bearing nylon 4N21	1	1
	4332	Yoke, D5	0	1
	4333	Yoke, splined 1000 RPM	1	0
	4334	Yoke, splined 540 RPM	1	0
	4335	Centralizer, nylon	1	1
	4336	Bearing nylon 4N20	1	1
	4337	Repair kit (1000 RPM Yoke)		
	4338	Repair kit (540 RPM Yoke)		

HARSH

Hydraulics
Unlimited Mfg. Co.
 600 OAK STREET • EATON, COLORADO 80615 • (303) 454-2291

MOBILE MIX

EFFECTIVE July 15, 1983

SCALE PARTS without SUB-FRAME

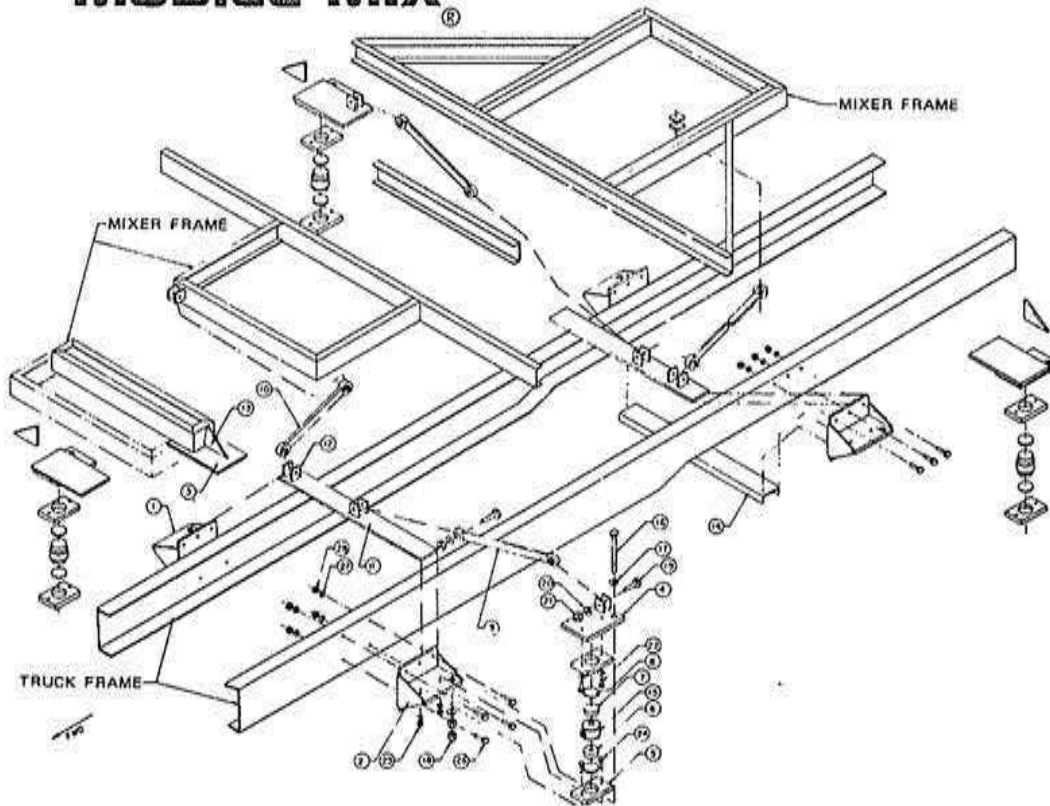

ITEM NO.	DESCRIPTION	NO. REQ'D.	PART NO.
	Indicator Stand Assembly (Specify Scale Type)		
	Weatherproof Indicator Box (Trailer Only)		
1	Bracket Assembly Scale, Right Hand	2	11877
2	Bracket Assembly Scale, Left Hand	2	11278
3	Plate, Scale Mounting, 1/2" x 7" x 12"	4	10706
4	Scale Plate (Cage Mounting), 1/2" x 6" x 9"	4	11116
5	Scale Plate (Load Cell Cage)	8	10814
6	Nut, Open Cell, Bottom	4	10859
7	Nut, Blind Cell, Top	4	10550
8	Disc, Shock Mount	8	11882
9	Sway Bar Assembly, Short	3	11878
10	Sway Bar Assembly, Long	1	11879
11	Strap, 1/2" x 4" x 34"	2	11881
12	Clevis	16	11177
13	Gusset	4	10780
14	Channell, 4" x 5.4 lb. x 36"	1	11880
15	Load Cell w/21" Lead (Dole)	4	100977
16	Hex. Hd. Cap Screw, 3/4" - 10 UNC x 8", Grade 5	4	100580
17	Washer, Flat, 3/4"	8	100556
18	Nut, Hex., 3/4" - 10 UNC	8	100658
19	Hex. Hd., Cap Screw, 1/2" - 16 UNF x 3", Grade 5	8	100825
20	Washer, Lock, 3/4"	8	100554
21	Nut, Hex., 1/2" - 16 UNF	8	100252
22	Hex. Hd. Cap Screw, 5/8" - 11 UNC x 1-1/2", Grade 5	8	100377
23	Hex. Hd. Cap Screw, 5/8" - 18 UNF x 2-1/2", Grade 5	8	100321
24	Nut, Hex., 5/8" - 18 UNF	8	100248
25	Hex. Hd. Cap Screw, 5/8" - 11 UNC x 2", Grade 5	14	100368
26	Washer, Lock, 5/8"	30	100273
27	Nut, Hex., 5/8" 11 UNC	14	100378

SCALE PARTS with SUB-FRAME

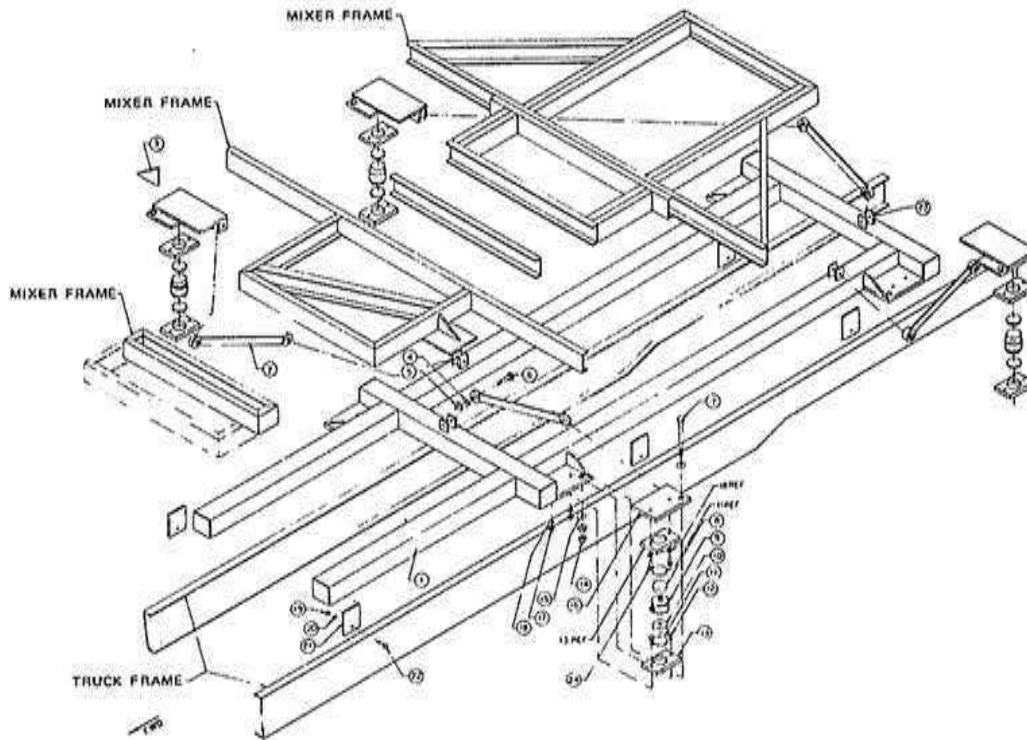

ITEM NO.	DESCRIPTION	NO. REQ'D.	PART NO.
1	Sub-Frame Assembly Complete (Less Scale)	1	
2	Sway Bar Assembly	4	A11878
3	Gusset	2	10780
4	Lockwasher, 3/4"	8	100554
5	Hex. Nut, 3/4" - 16 UNF	8	100252
6	Hex. Hd. Cap Screw, 3/4" - 16 UNF x 3", Grade 5	8	100825
7	Hex. Hd. Cap Screw, 3/4" - 10 UNC, 8", Grade 5	4	100580
8	Nut, Blind Cell	4	10558
9	Load Cell w/21' Lead (Dole)	4	100977
10	Nut, Open Cell	4	10559
11	Disc, Shock Mount	8	11852
12	Hex. Hd. Cap Screw, 5/8" - 18 UNF x 2 1/2", Grade 5	8	100321
13	Scale Plate (Load Cell Cage)	8	10814
14	Hex. Nut, 3/4" - 10 UNC	8	100658
15	Flat Washer, 3/4"	8	100556
16	Scale Plate (Cage Mounting)	4	11116
17	Hex. Nut, 5/8" - 18 UNF	8	100248
18	Lockwasher, 5/8"	16	100273
19	Hex. Nut, 1/2" - 20	6	100250
20	Lockwasher, 1/2"	6	100272
21	Mounting Strap	6	10918
22	Hex. Hd. Cap Screw, 1/2" - 20 UNF x 1 1/2", Grade 5	6	100226
23	Clevis	16	11177
24	Hex. Hd. Cap Screw, 5/8" - 18 UNC x 1 1/2", Grade 5		100377
	Indicator Stand Assembly (Specify Scale Type)		
	Weatherproof Indicator Box (Trailer Only)		

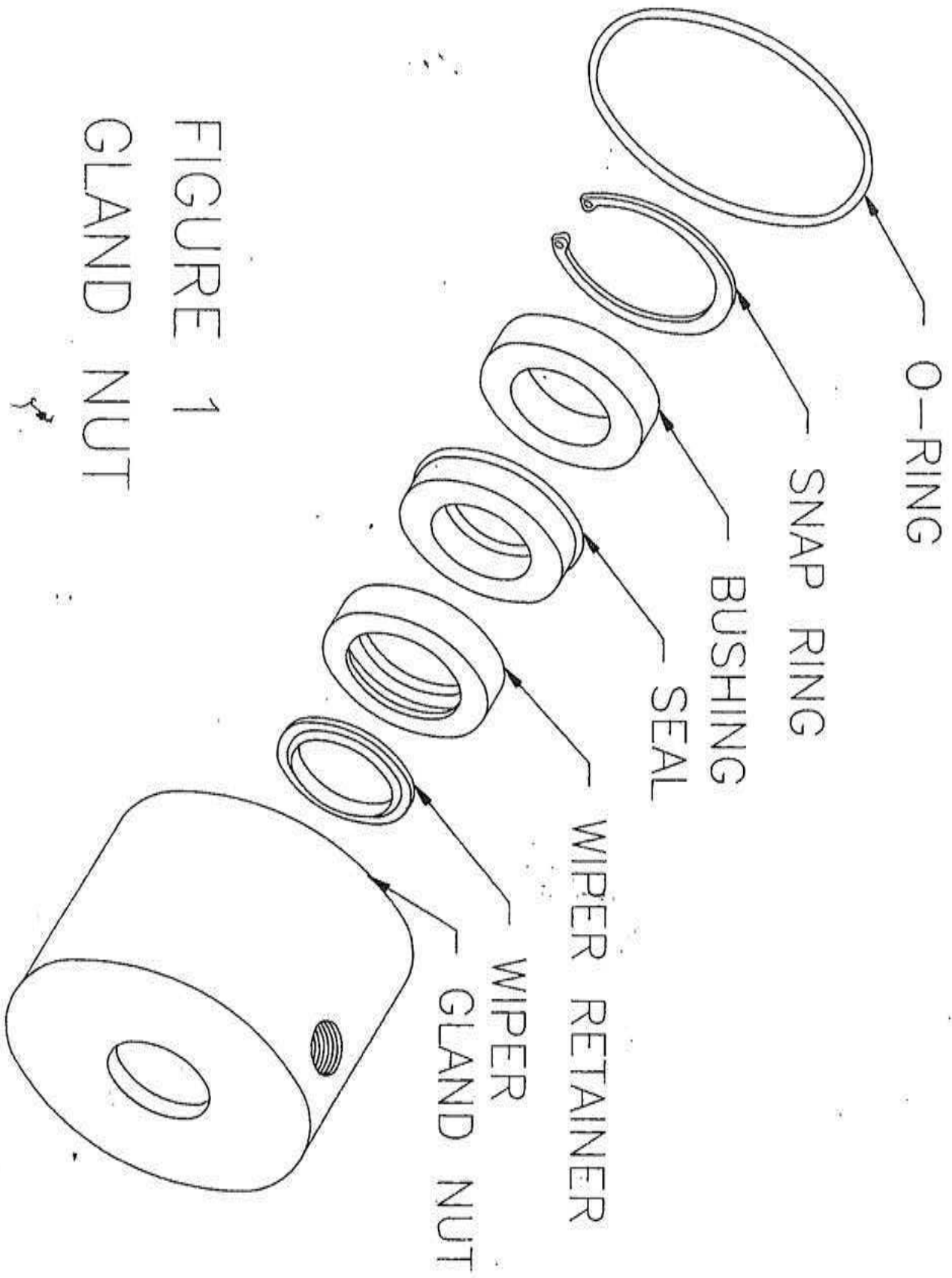

FIGURE 1
GLAND NUT

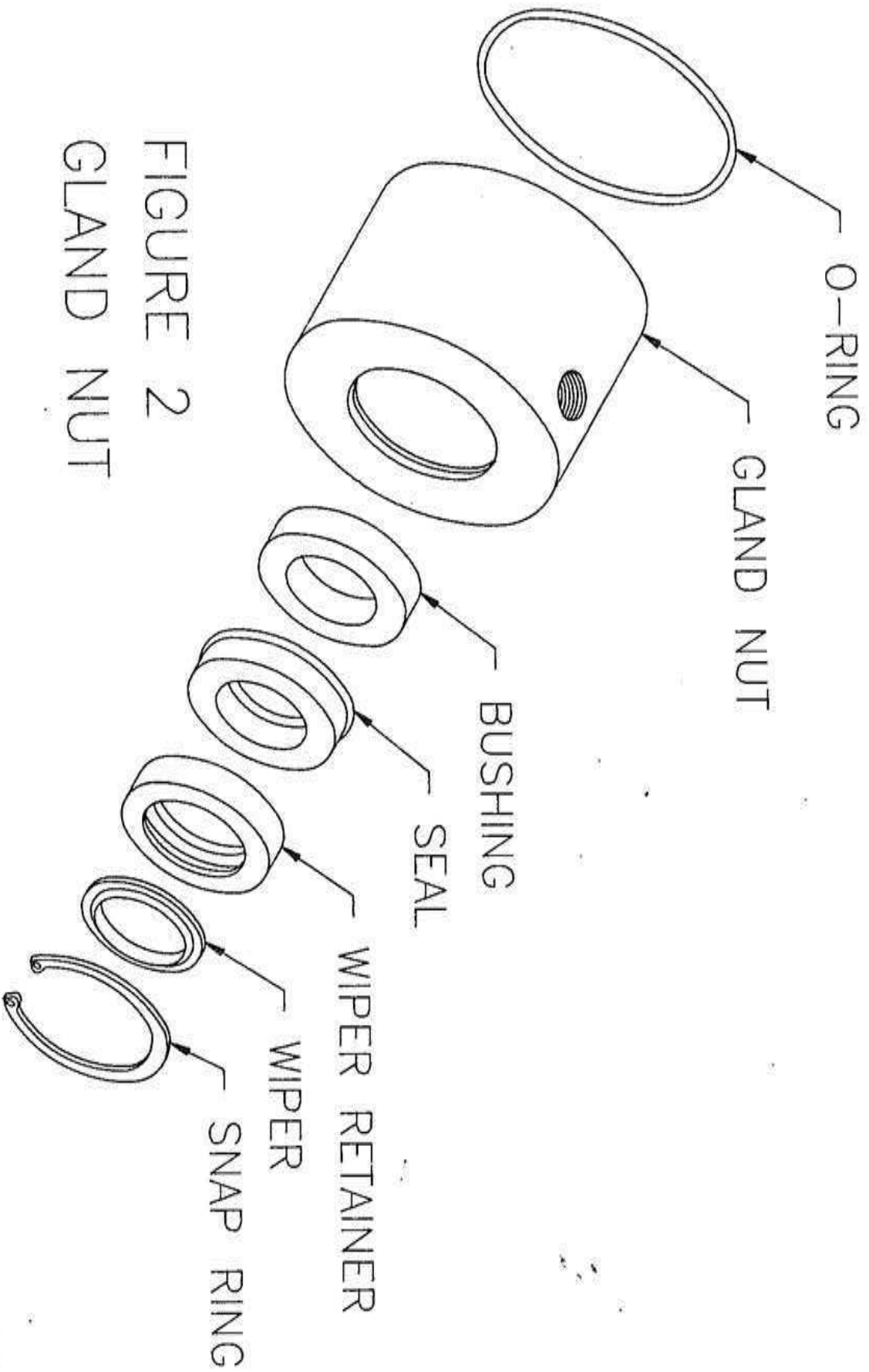

FIGURE 2
GLAND NUT

DISCHARGE SYSTEMS

FOUR BASIC OPTIONS USED

1. Single auger discharge.
2. Dual auger discharge with one drive gearbox located underneath mixer on the passenger side.
3. Dual auger discharge with two gearboxes mounted directly to the back of the discharge.
4. Dual auger discharge with one gearbox mounted beside the discharge (in front).

Determine your desired option then refer to the correct breakdown.

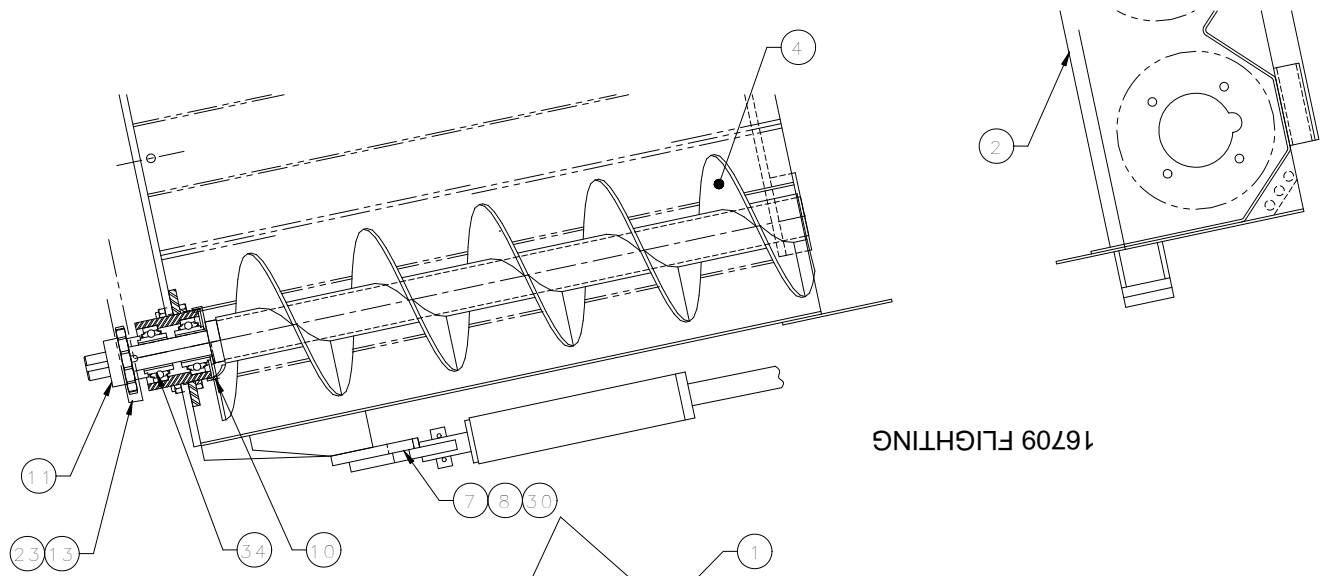

NOTE:
 DRILL HANGER TO MATCH DIS.
 BOTTOM AFTER FITTING TO MIXER.

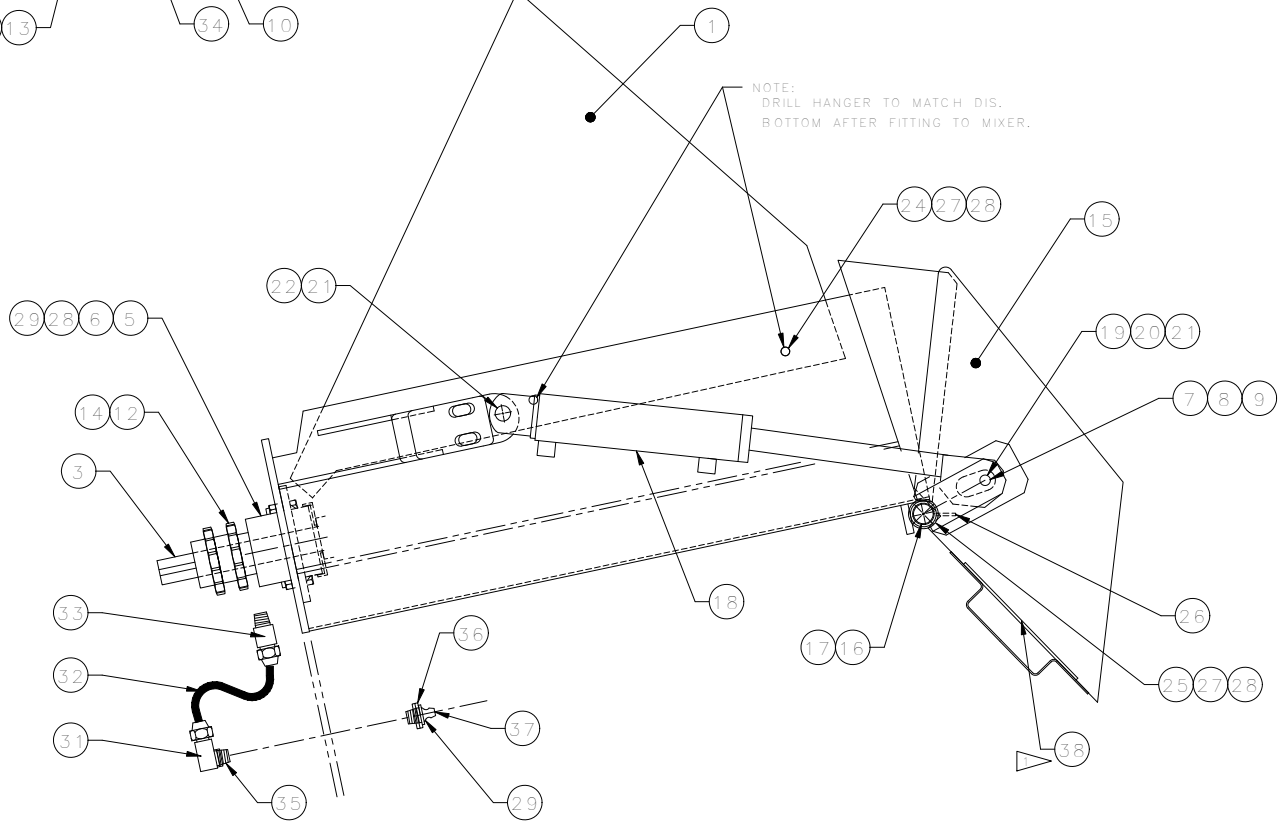

DETAIL: GREASE BANK
 SCALE: HALF
 TYP 3 PLCS

NOTES:

1 ITEMS 38, 39, 40 & 41 TO BE SHIPPED WITH DISCHARGE ASSY

1	1	41	9804	MOUNTING DETAIL,SINGLE TO TRIPLE DIS CONV
1	1	40	9803	INSTRUCTION SHEET,SINGLE TO TRIPLE DIS CONV
1	1	39	18377	BRACKET, DISCHARGE SUPPORT
1	1	38	18376	PLATE, MAGNET COVER TOP
REF	37	101953	ZERK TIP REPLACEMENT	
6	36	100838	WASHER,FLAT 1/2	
6	35	100300	WASHER,FLAT 3/8	
6	34	16818	BEARING, WIDE INNER RING, 1 SEAL	
3	33	102759	FITTING, COMPRESSION 1/8NPTx1/4TUBE STR.	
40"	32	6060031	TUBING,ALUM. Ø1/4	
3	31	102753	FITTING, COMPRESSION 1/8NPTx1/4TUBEx90°	
2	30	300889C	SCREW,HEX HD CAP 1/2-13UNC x 1 3/4	
3	29	102454	GREASE FITTING 1/8 NPT(F)	
17	28	100271	WASHER, LOCK 3/8	
17	27	100254	NUT,HX 3/8-16UNC	
1	26	10714	LINK, HALF 3/16 LOG CHAIN	
1	25	300898	SCREW,HX HD CAP 3/8-16UNC x 2	
4	24	102096	SCREW,CARRIAGE HD 3/8-16UNC x 1	
2	23	101897	CHAIN,#60 x 39 PITCHES W/ CONN & OFFSET	
2	22	100174	COTTER PIN 3/16 x 1 1/2 LG	
1	21	14533	PIN, Ø3/4 x 2 LG	
2	20	14574	BUSHING, SHORT	
1	19	15708	CYLINDER MNT TUBE	
1	18	A17370	CYLINDER ASSY, DROP CHUTE	
1	17	101896	SCREW,SQ HD SET CUP POINT 3/8-16UNCx1	
1	16	15276	PIN, DROP CHUTE HINGE Ø1 x 35 1/2 LG	
1	15	A15933	DROP CHUTE ASSY	
1	14	15309	KEY,SQ 5/16 x 1 3/4 LG	
2	13	15308	KEY,SQ 5/16 x 1 1/4 LG	
1	12	101700	SPROCKET,DS60B13 1 1/4 BORE	
2	11	100072	SPROCKET H60B13 1 1/4 BORE	
3	10	16608	CAP,DISCHARGE BEARING 3 3/4 OD x 1 1/4	
1	9	101735	SCREW,HEX HD CAP 1/2-13UNC x 2 1/2	
3	8	100272	WASHER, LOCK 1/2	
3	7	300826	NUT,HX 1/2-13UNC	
12	6	100240	SCREW,HX HD CAP 3/8-16UNC x 1 1/4	
3	5	A14590	AUGER BEARING HOUSING ASSY	
2	4	A16722	DISCHARGE AUGER ASSY 37 1/8 LG.	
1	3	A16710	DISCHARGE AUGER ASSY 39 LG.	
1	2	A16703	DISCHARGE BOTTOM ASSY	
2	1	16479	PLATE, DISCHARGE HANGER	
		A7483	DISCHARGE KIT	

CAD DRAWING--DO NOT REVISE MANUALLY
REPORT ERRORS TO ENGINEERING DEPARTMENT

QTY	ITEM	PART NO	DESCRIPTION	
MATL	SIZE	UNIT	MATL NO	MATERIAL DESCRIPTION
CUSTOMER M. M.		RELEASE ECO#90-6-11		
TITLE DISCHARGE GROUP,SINGLE TO TRIPLE CONVERSION		FINAL ASSY		
SIZE D	DRAWING NO A7483	REV J	DRAWN BY: SJC	
COMP NO 7000/7400		SCALE: 1/4	DATE: 11/29/02	

Unless Otherwise Specified:
All Dimensions in Inches
All Machine Surfaces
12.5
Break All Sharp Corners
Ø10-Max.
Tolerances:
Dec. XX.03
XX.005
Frac. 1/16"
Angles 1°

CHECKED BY: APPROVED BY:

600 OAK AVE. DATE: DATE:
EATON, CO. 80615

OPERATION INSTRUCTIONS

Engaging Mixer:

- a) Warm engine adequately;
- b) Engage Mixer with engine idling.

2. Loading Mixer:

- a) ALWAYS LOAD MIXER with the AUGERS TURNING;
- b) Speed up engine adequately to keep augers turning while loading. (The necessary en-

gine R.P.M. will be learned through actual use.)

c) Feed Mixing Instructions:

- (a) When feeding grain mixtures — add grain first;
- (b) When adding a liquid to the load- add liquid last;
- (c) AVOID long cut feed;
- (d) AVOID chunky material.

DISCHARGE CHUTE SYSTEM

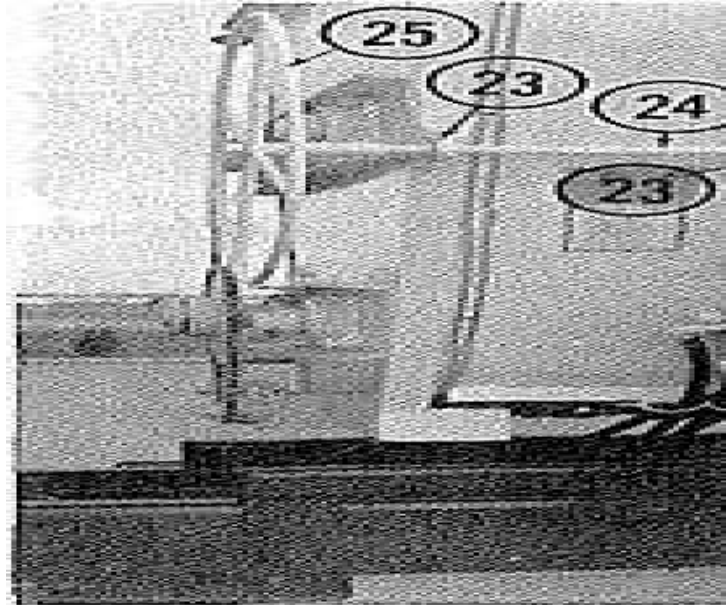
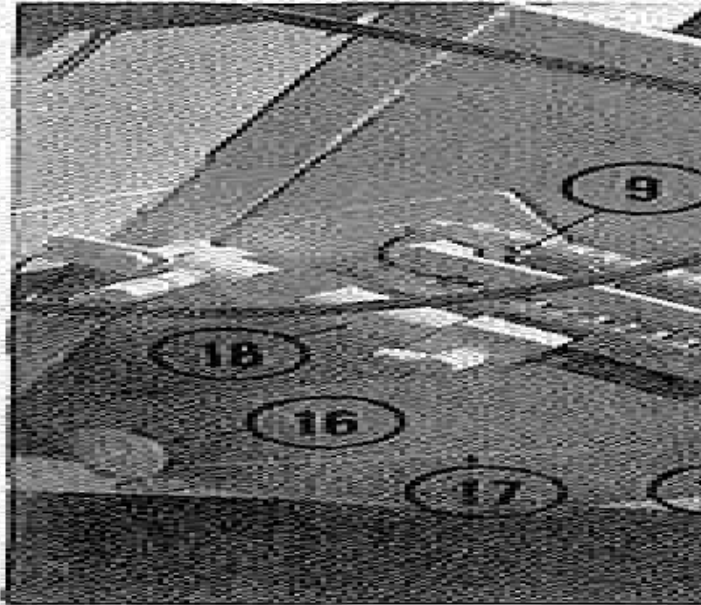

**Repair Part (Flying only)*

SINGLE AUGER DISCHARGE SYSTEM

ITEM NUMBER	PART NUMBER	DESCRIPTION	NO. REQ'D	
			MODEL 300F	MODEL 350F
**1	11067	Drop Chute- Flat Bottom (as shown) A10704-round btm.	1	1
2	11068	Adapter (must cut to fit)	1	1
**3	11070	End Hinge Tubing	2	2
**4	11069	Center Hinge Tubing	5	5
**5	11071	Hinge Shaft W/Out Hyd.	1	1
**5	11387	Hinge Shaft W/Hyd.	1	1
	100985	Magnet, 18"	1	1
	A16374	Magnet guard	1	1
7	10742	Discharge Bottom 1/4"- Round Spout (not shown)	1	1
	11849	Discharge Bottom 1/4"- Flat Spout (as shown)	1	1
	10719	Discharge Bottom 10 Ga- Flat Btm. Spout (as shown)	1	1
9	100092	Sprocket (H60B13 x 1)	4	4
10	10628	Drop Chute Chain (#60 x 60 %" Lg.)	1	1
13	11072	Drop Chute Stop Collar	1	1
14	A11075	Cylinder to Chain Mount	1	1
16	100307	Cable Pulley	1	1
17	7070227	Control Cable (3/16" Dia. x 84" Lg.)	84 ¹¹	84 ¹¹
18	A10155	Cylinder Assy.- Drop Chute (4 %"Stroke)		
	A12111	Cylinder Assy.- Drop Chute (8" Stroke)		
20	A10553	Auger Assy. - Discharge	1	1
21	10801	Right Hand Flighting (3/16" x 20")	1	1
21	10809	Right Hand Flighting (Eiipsed)	1	1
22	A10562	Discharge Door Assy.	1	1
23	100058	Bearing Pillow Block (1" Dia.)	3	3
24	10544	Door Shaft (1" Dia. x 54" Lg.)	1	1
25	A10673	Wheel Assy.- Discharge Door	1	1
26	A10132	Cylinder Assy.- Discharge Door (25" Stroke)	1	1
	10676	Reinforce Plate Bearing		
	A10810	Cylinder Mount, Door--Upper	1	1
	10713	Cylinder Mount, Door--Lower	2	2
	A12751	Cylinder Mount, Spout	1	1
	10676	Back Plate		

A10132	Door Cylinder	A10155	4" Stroke Cylinder
10092	Piston	10092	Piston
10134	Shaft	10156	Shaft
A10136	Body	A10135	Body
A12047	Gland Nut	A12047	Gland Nut
Seal kits used	<i>-one each needed</i>	A12111	8" Stroke Cylinder
A9409	S.K. Gland Nut	10092	Piston
A9252	S.K. Piston	12114	Shaft
		A121112	Body
		12047	Gland Nut



GEAR BOX DRIVE TO SINGLE AUGER DISCHARGE SYSTEM

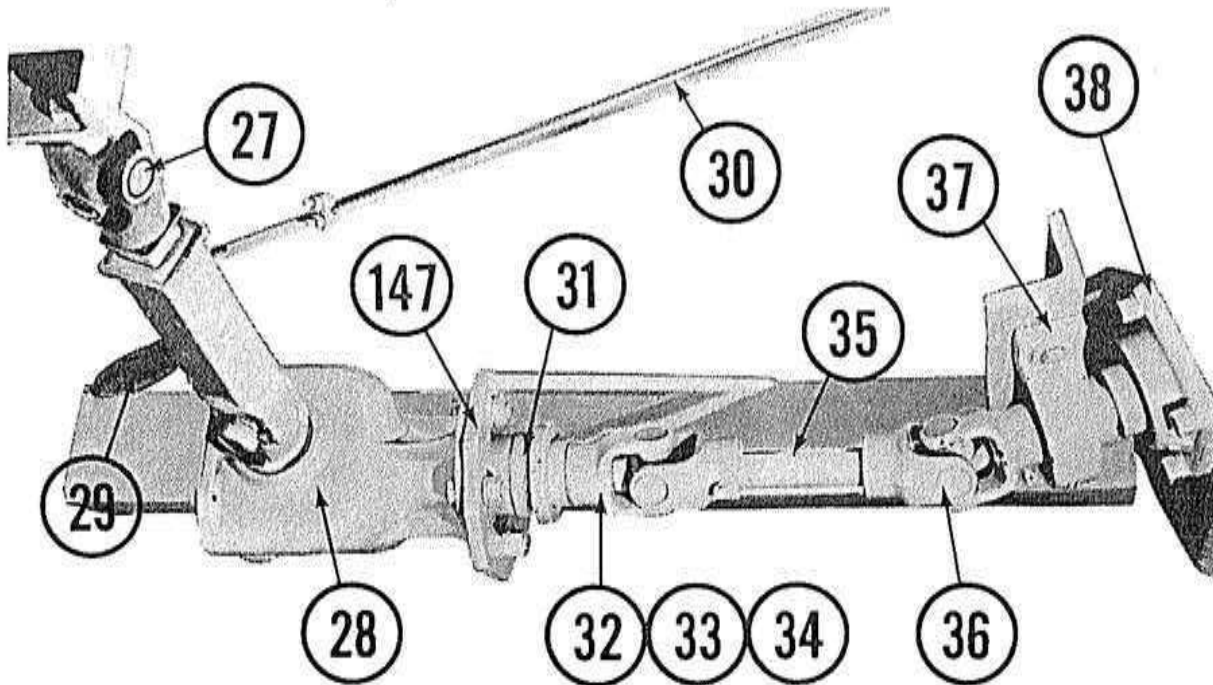

ITEM NUMBER	PART NUMBER	DESCRIPTION	NO. REQ'D	
			MODEL 300F	MODEL 350F
27	100491	U-Joint (1 ¼" Rnd. x 1" Sq.)	1	1
28	100305	Gear box - New Holland	1	1
29	100446	Tension spring (1 ¼" Dia. x 5 ½" Lg.)	1	1
30	100448	Tension spring (3/8" Dia. x 16" Lg.)	1	1
31	10920	Gear box, output shaft collar - New Holland	1	1
32	10626	U-Joint, special yoke	1	1
33	100662	U-Joint, cross	1	1
34	100659	U-Joint, yoke (1 ¼" Dia.)	1	1
35	10549	Shaft (1 ¼" Dia. x 7 ½" Lg.)	1	1
36	100490	U-Joint (1 ¼" Rnd. x 1 ¼" Rnd.)	1	1
37	100049	Bearing, pillow block (1 ½" Dia.)	1	1
38	100054	Bearing, flanged (1 ½" Dia.)	1	1
39	100661	Nut 3/4-16 UNF	1	1
40	100663	Washer 3/4	1	1
147	10575	Mounting plate - New Holland gear box	1	1
41	4107	Cross kit	1	1
42	300904C	Bolt 1/2" -13x2"	6	6
43	300826C	Nut 1/2" -13	6	6

OPERATION INSTRUCTIONS

1. Engaging Mixer:

- Warm engine adequately;
- Engage Mixer with engine idling.

2. Loading Mixer:

- ALWAYS LOAD MIXER with the AUGERS TURNING;
- Speed up engine adequately to keep augers turning

while loading. (The necessary engine RPM will be learned through actual use).

c. Feed Mixing Instructions:

- When feeding grain mixtures — add grain first;
- When adding a liquid to the load — add liquid last;
- AVOID long cut feed;
- AVOID chunky material.

DISCHARGE CHUTE SYSTEM

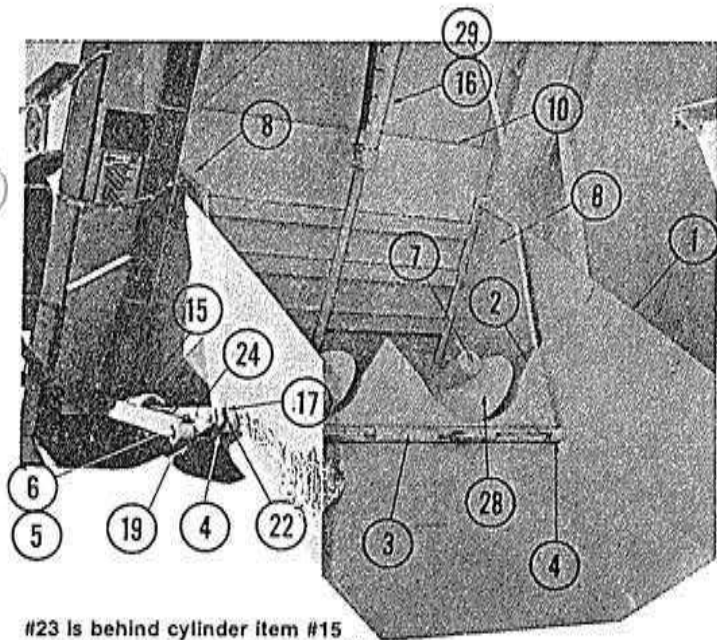

HYDRAULIC

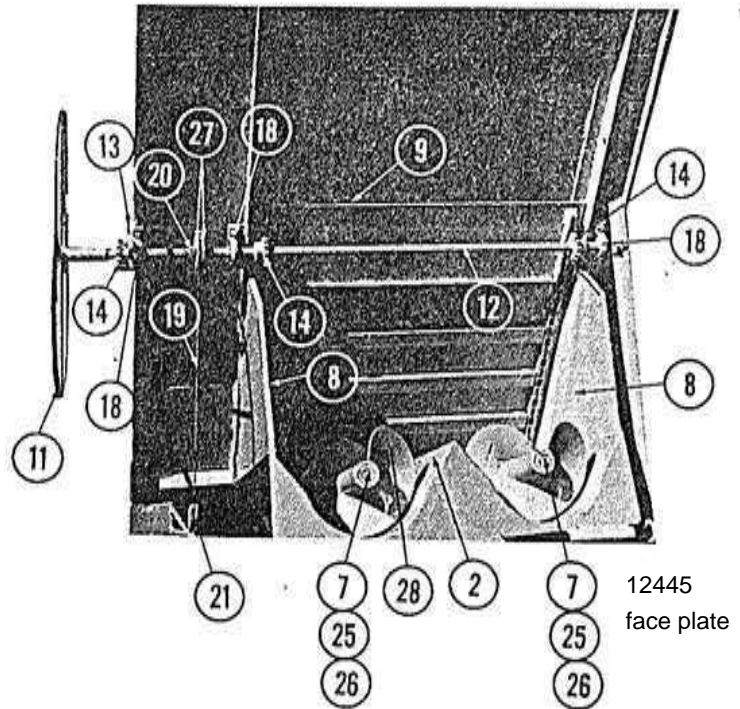

MANUAL

**DUAL AUGER DISCHARGE CHUTE SYSTEM
W/ GEAR BOX UNDER MIXER/PASSANGER SIDE**

ITEM NUMBER	PART NUMBER	DESCRIPTION	WITH HYDRAULICS	MANUAL
1	12458	Drop chute	1	1
2	A12457	Discharge bottom	1	1
3	12452	Hinge tube center	5	5
4	11070	Hinge tube end	2	2
5	12811	Hinge shaft	-	1
6	12441	Hinge shaft	1	-
7	A12444	Auger assy. discharge	2*	2*
10	A12442	Discharge door assy.	1	-
11	A10673	Discharge wheel assy.	-	1
12	12810	Wheel shaft	-	1
14	100092	Sprocket H60B13 x 1"	-	3
15	A12111	Cylinder drop chute (8" Stroke)	1	-
	A12112	Body (for A12111)		
	12114	Shaft (for A12111)		
	12047	Gland nut (for A12111, AND A12474)		
	10092	Piston (for A12111, AND A12474)		
	A9252	Seal kit, piston (for A12111, and A12474)		
	A9409	Seal kit, gland nut (for A12111, and A12474)		
16	A12474	Cylinder door (23 1/8" Stroke)	1	-
	A12476	Body (for A12474)		
	12477	Shaft (for A12474)		
17	12122	Tube roller	1	-
18	100058	Bearing 1" bore	-	3
19	7070227	Air craft cable 3/16"	84"	84"
20	100306	Cable clamp	2	4
21	100307	Pulley	1	2
22	A12463	Drop chute activator assy.	1	-
23	12448	Brace	1	-
24	A12450	Connector arm assy.	1	-
25	100054	Bearing RCJ 1 1/2	2	2
26	100049	Bearing RAK 1 1/2	2	2
27	10723	Guide cable spool	-	2
28	12460R	Flighting discharge 3/16" x 12 x 14 RH	2*	2*
29	A11318	Adapter assy.	1	-
	A10810	Cylinder Mount, Door--Upper	1	1
	12435	Cylinder Mount, Door--Lower	2	2
	A14441	Cylinder Mount, Spout	1	1

* No. Required for Each Auger A12444

DISCHARGE GEAR BOX

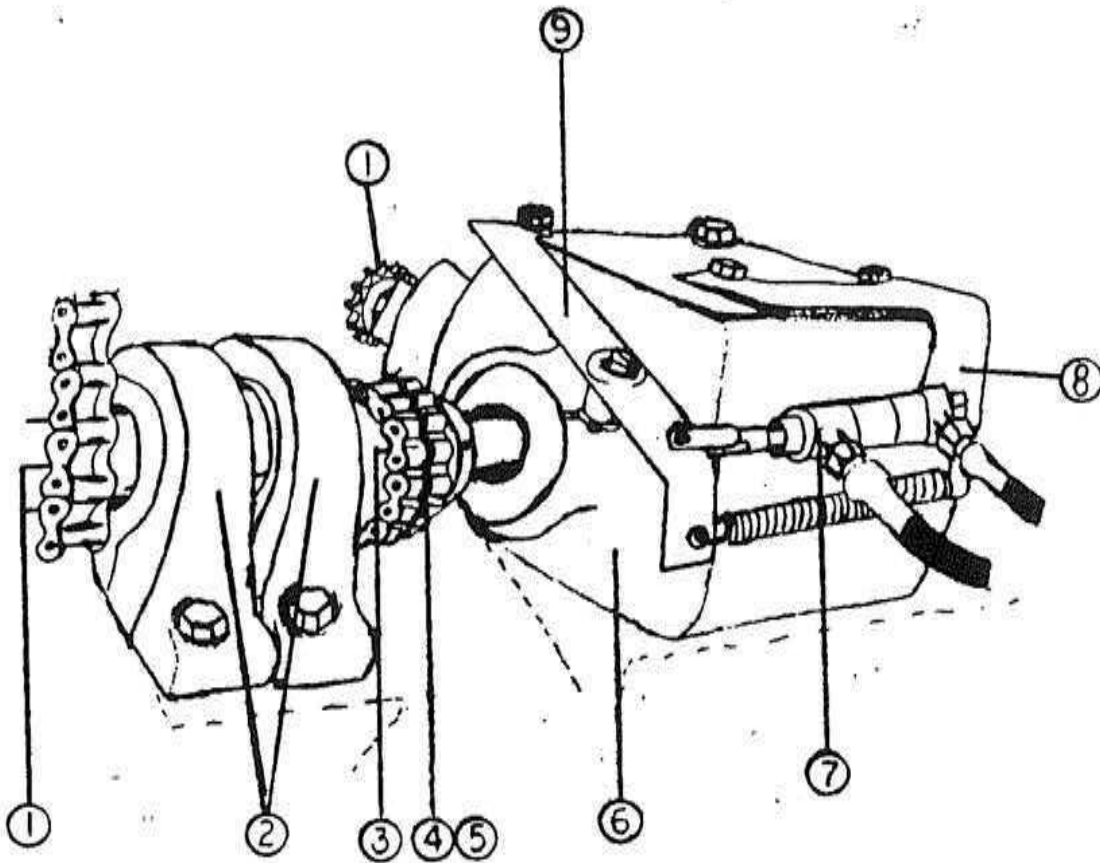

ITEM NO	PART NO	DESCRIPTION	QTY REQD
1	100072	SPROCKET	2
2	100055	PILLOW BLOCK BEARING	2
3	10549	SHAFT	1
4	101875	CHAIN FOR COUPLING	1
	101994	CHAIN COUPLING HALF	2
6	101684	GEAR BOX	1
7	101886	CYLINDER	1
8	14427	PLATE, CYLINDER MOUNT	1
9	A14456	GEAR SHIFT ARM ASSEMBLY	1

GEAR BOX DRIVE TO DISCHARGE SYSTEM

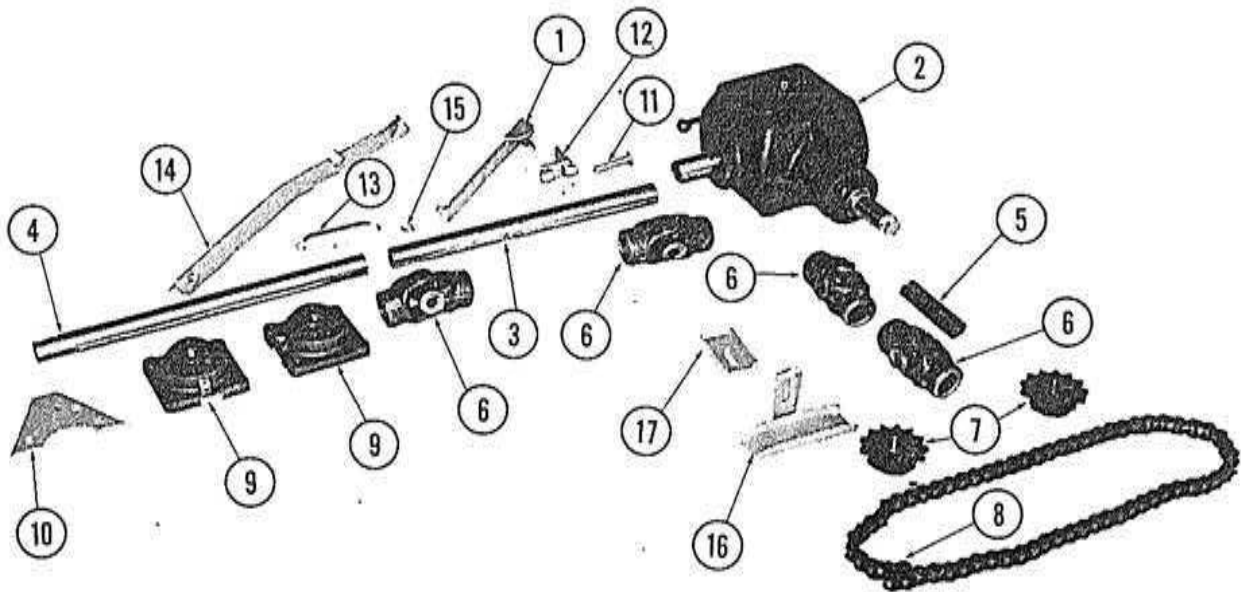

ITEM NUMBER	PART NUMBER	DESCRIPTION	WITH HYDRAULICS	WITHOUT HYDRAULICS
1	A12802	Gear Box Actuator Arm	1	—
2	101063	Gear Box	1	1
3	10550	Drive Shaft	1	1
4	12453	Drive Shaft	1	1
5	12451	Drive Shaft	1	1
6	100490	U-Joint 1 1/4" Rnd. - 1 1/4" Rnd.	4	4
7	100072	Sprocket H60B13 - 1 1/4"	2	2
8	12461	Chain (#60 x 48 3/4" Lg.)	1	1
9	100053	Bearing RCJ 1 1/4"	2	2
10	10427	Bracket - Idler	1	1
11	A12801	Pin Assy.	1	1
12	A12806	Bracket Actuator Arm	1	1
13	100446	Spring (1 1/8" Dia x 5 1/2" Lg.)	—	1
14	A12704	Gear Box Activator Arm	—	1
15	10714	Half Chain Link	—	1
16	A12469	Bracket Assy. Chain Tensioner	1	1
17	12466	Channel Mount	1	1

DOUBLE GEAR BOX DISCHARGE SYSTEM

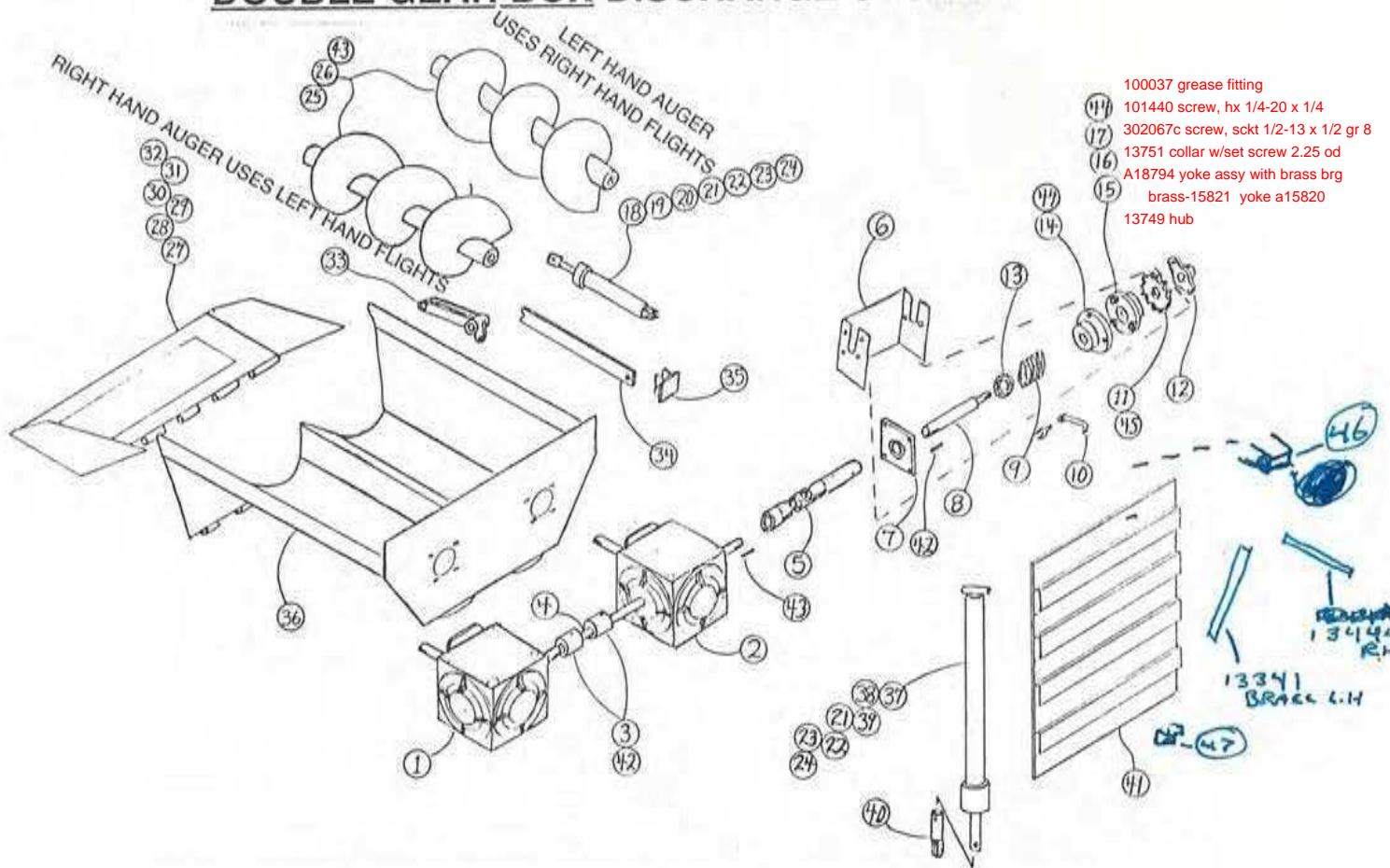

ITEM	PART	DESCRIPTION	QTY	ITEM	PART	DESCRIPTION	QTY
1	302088C	Gear box (2-Shaft)	1	25	A13760	Auger 36" FRONT	1
2	302111C	Gear box (3-Shaft)	1	25	A13763	Auger 36" BACK	1
3	101437	Coupling	2	26	12460R	Flighting, 3/16" x 12 R.H.	
4	35069C	Shaft	1	26	12460L	Flighting, 3/16" x 12 L.H.	
5	302086C	U-Joint, double pvt.	1	**27	13741	Drop chute	1
6	13746	Bracket	1	28	101249	Magnet 24"	1
7	302072C	Bearing, flanged 1 1/4	1	29	A15730	Guard for magnet	1
8	13745	Shaft, 1 1/2 x 18 1/2 to 1"	1	**30	12452	Hinge tube	
9	302090C	Spring, compression	1	**31	11070	Hinge tube	4
10	A14245	Cable guide assy.	1	**32	12441	Shaft, hinge 1" x 46"	1
	101267	Yoke	2	33	A13402	Chute activator	1
11	101448	Sprocket, H6013 - 1 1/2	1	34	12448	Brace, drop chute	1
12	101442	Bearing, flanged 1	1	35	A12751	Bracket cylinder mount	1
13	101441	Collar 1 1/4 set	1	36	A13733	Bottom, 26" discharge	1
14	A13747	Clutch-sliding half	1	36	A13734	Bottom, 36" discharge	1
15	A13752	Clutch-fixed half	1	37	A13882	Cylinder for door	1
16	302067C	Screw, socket head	6	38	A13883	Body (for A13882)	
17	15966	Bushing brass		39	12477	Shaft (for A13882)	
18	A12111	Cylinder - drop chute	1	40	A11318	Cylinder adapter	1
19	A12122	Body (for A12111)		41	A12442	Discharge door	1
20	12114	Shaft (for A12111)		42	34988C	Key 1/4 sq. x 3 1/2	
21	12047	Gland nut		43	34989C	Key 1/4 sq. x 2"	
22	10092	Piston		44	13766	Key 1/4 sq. x 4"	
23	A9409	Seal kit - gland nut		45	13855	Key, stepped 3/8" - 1/4"	
24	A9252	Seal kit - piston		46	A10810	Cylinder mount - upper	1
25	A13728	Auger 26" FRONT	1	47	12435	Cylinder mount - lower	2
25	A13729	Auger 26" BACK	1		A14441	Cylinder mount assy, spout	1

DUAL AUGER DISCHARGE W/GEARBOX BESIDE DISCHARGE

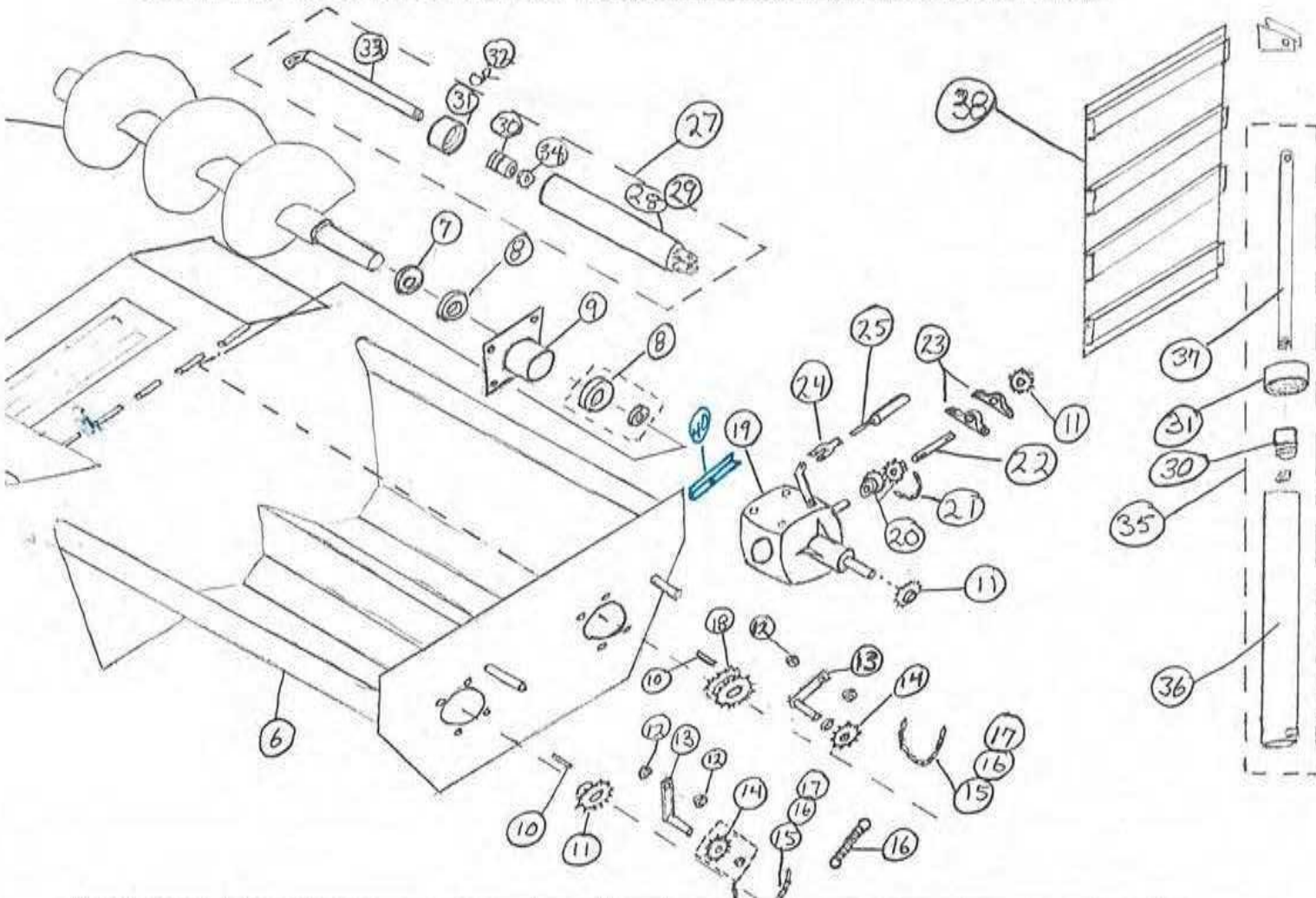

ITEM	PART	DESCRIPTION	QTY.	ITEM	PART	DESCRIPTION	QTY.
1	A14448	Drop chute	1	21	101875	Chain for coupler	1
2	101249	Magnet 28"	1	22	10549	Shaft	1
3	A15622	A15730 Guard	1	23	100055	Bearing, 1 1/4 pillow block	2
4	A14455	Auger	2	24	15083	Clevis w/ 1/4" UNC	*
5	12460L	Flighting left hand (2 per auger)	4	25	101686	Cylinder	*
6	A14412	Main bottom	1	26	A7484	Cable kit (replacement for cyl.)	*
7	15617	Dust cap (bearing protector)	2	*27	A15965	Cylinder (drop chute) REPLACES A14444	1
8	16818	Bearing insert 1 1/4 (2 per auger)		*27	A14444	Cylinder (drop chute)	
9	A14383	Housing, bearing	4	28	A15957	Body w/ internal threads(A15956)	*
10	10983	Key, sq. 5/16 x 2	2	29	A14445	Body w/ external threads(A14444)	*
11	100072	Sprocket, H60 B13 x 1 1/4	AR	30	10092	Piston	
12	101830	Set collar 1 1/4"	3	31	12047	Gland nut w/ internal threads (A14444)	*
13	A15013	Tensioner arm	AR	32	14503	Gland nut w/ external threads(A15956)	*
14	A15133	Sprocket 60A13 w/ 3/4" bearing	2	33	A14507	Cyl shaft (both A14444, A15965)	*
15	7070505	Chain #60 (per foot)	2	34	100248	Nut	
16	100292	Connector link #60	AR	35	A13882	Cylinder (door)	1
17	100673	Offset link #60	AR	36	A13883	Body (A13882)	
18	101700	Sprocket, double 60B13 1 1/4	AR	37	12477	Cylinder shaft (A13882)	
19	101684	Gear box A-15	1	38	A12442	Door ass'y.	1
20	101994	Coupling half (sprt)	1	39	A10810	Cylinder mount, door -- Upper	1
			2		12435	Cylinder mount, door -- Lower	2
	A9252	Seal kit, piston		A9400		Seal kit, Gland Nut-Internal Style	*
				A9409		Seal kit, Gland Nut-External Style	*

40 14570 AUGER, GUARD MDT

A7084

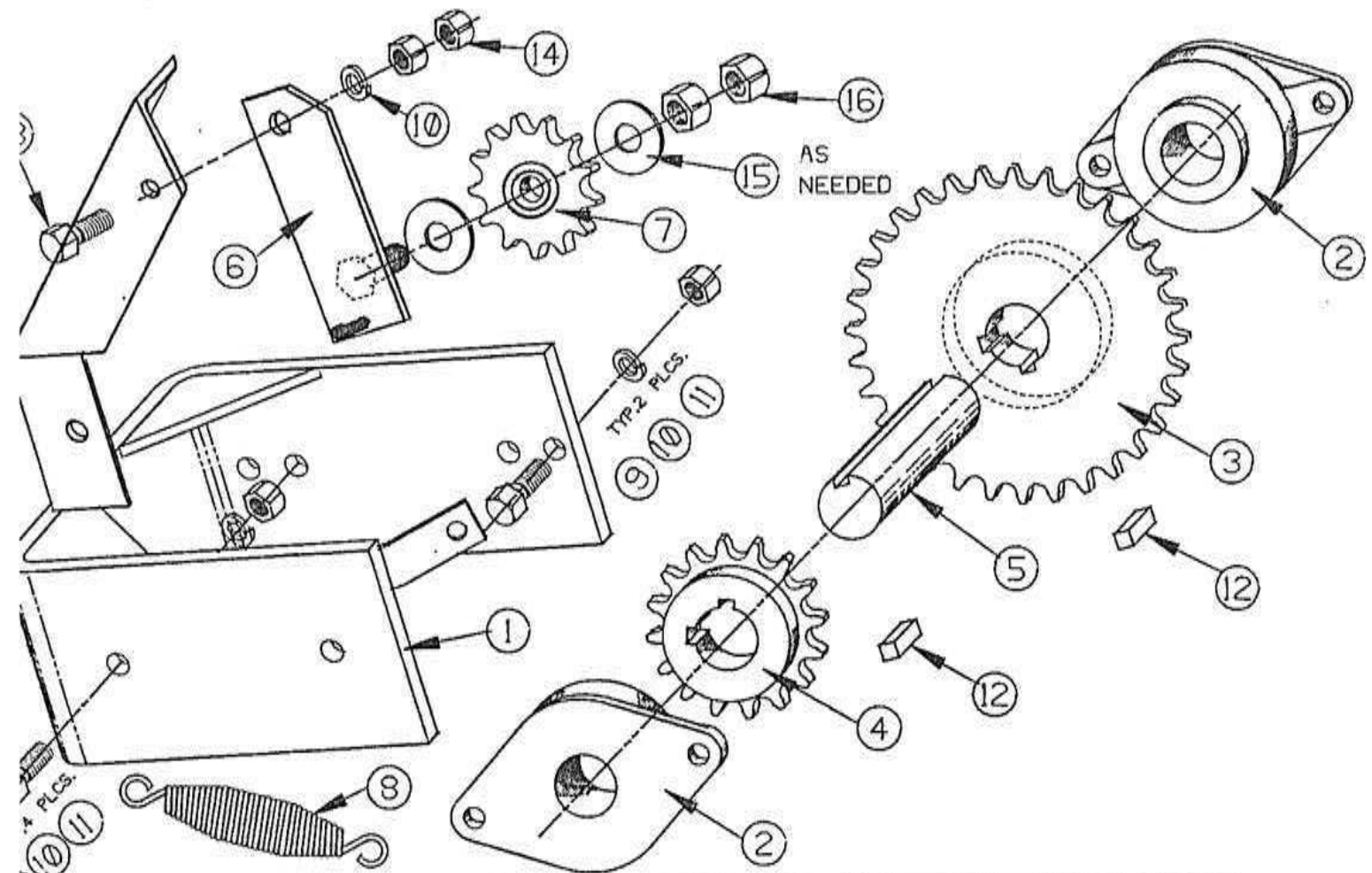

ITEM NO.	PART NO.	DESCRIPTION	NO. REQ'D.
16	100378	NUT, HEX 5/8-11UNC	2
15	100179	WASHER, FLAT 5/8	4
14	300826	NUT, HEX 1/2-13UNC	2
13	101444	SCREW, HEX HD. CAP 1/2-13UNCx 1 1/2	1
12	34890	KEY, SQ. 3/8x2"	2
11	100250	NUT, HEX 1/2-20UNF	6
10	100272	LOCKWASHER 1/2	7
9	100230	SCREW, HEX HD. CAP 1/2-20UNF x 2"	6
8	100446	SPRING 1 1/8 DIA.x 5 1/2"	1
7	101314	SPROCKET, HB60A13 w/5/8 BEARING	1
6	A14250	MOUNT ASS'Y IDLER SPROCKET	1
5	14249	SHAFT, JACK 1 1/2 DIA.	1
4	101610	SPROCKET, H60B16	1
3	101609	SPROCKET, H60B32	1
2	302071	BEARING, FLANGE RCJT 1 1/2"	2
1	A14239	JACK SHAFT MOUNT CHANNEL ASS'Y	1

JACK SHAFT REPAIR KIT

H11 # 9371

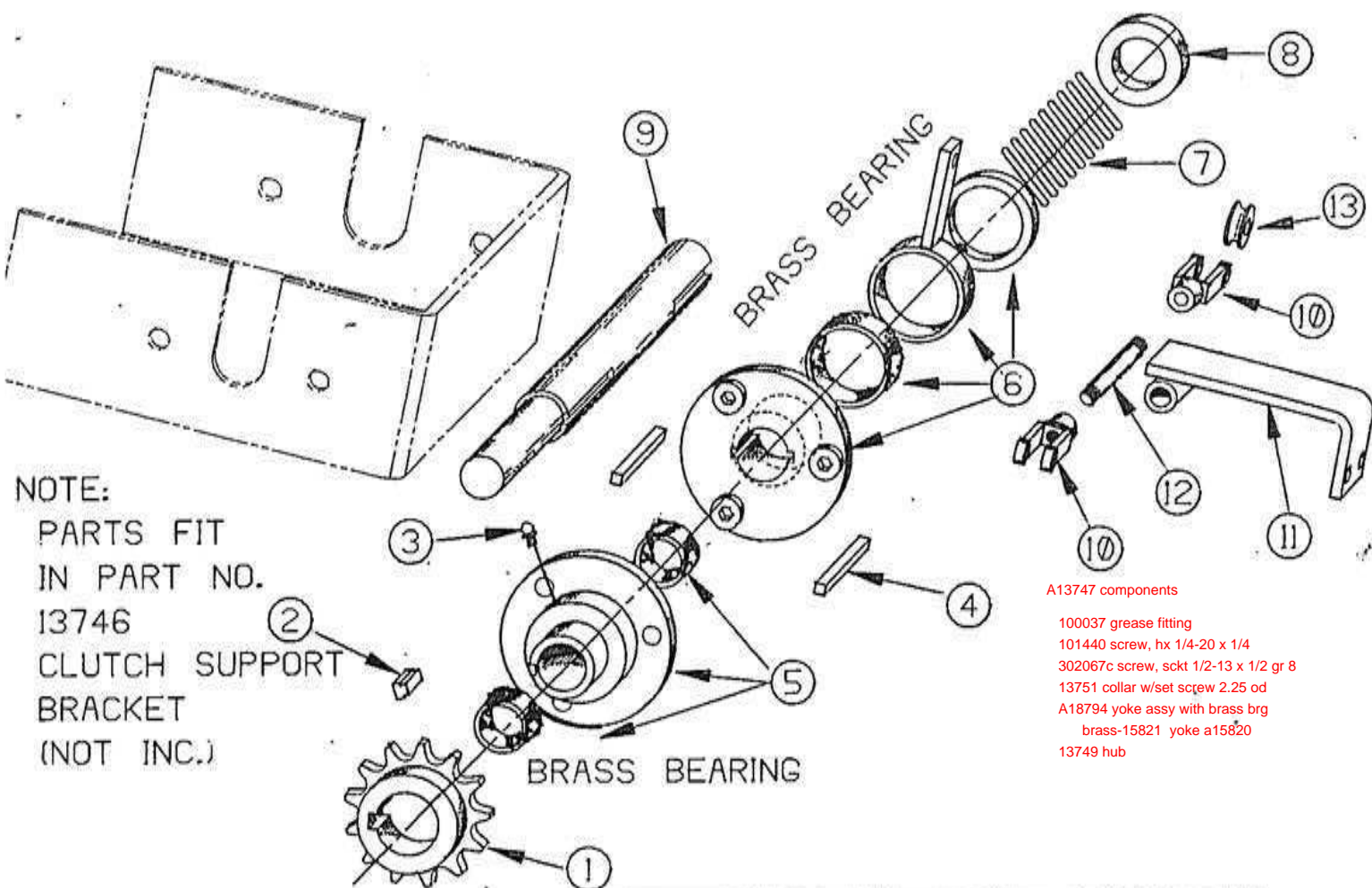

NOTE:
 PARTS FIT
 IN PART NO.
 13746
 CLUTCH SUPPORT
 BRACKET
 (NOT INC.)

- A13747 components
- 100037 grease fitting
 - 101440 screw, hx 1/4-20 x 1/4
 - 302067c screw, sckt 1/2-13 x 1/2 gr 8
 - 13751 collar w/set screw 2.25 od
 - A18794 yoke assy with brass brg
 - brass-15821 yoke a15820
 - 13749 hub

ITEM NO.	PART NO.	DESCRIPTION	NO. REQ'D.
1	101448	SPROCKET, H6013 x 1 1/2 BORE	1
2	13855	KEY, STEPPED 3/8 x 1/4 x 1 1/4 LG.	1
3	100037	GREASE FITTING	1
4	13766	KEY, 1/4 SQ. x 4" LG.	2
5	A13752	CLUTCH ASS'Y (FIXED)	1
6	A13747	CLUTCH ASS'Y (SLIDING)	1
7	302090	SPRING, COMPR. 1 7/8 O.D.x 3 3/8 LG.	1
8	101441	COLLAR, SET SCREW (1 1/4 I.D.)	1
9	13745	SHAFT, DISCHARGE DRIVE	1
10	101267	YOKE END	2
11	A14245	CABLE PULL ROD GUIDE ASS'Y	1
12	14248	ROD,CABLE PULL	1
13	14252	WHEEL, 1" PULLEY	1
14			

CLUTCH REPAIR KIT-H.U.#9398

AUGERS

300 - 302, 350 - 354, 400 - 406, 458

12 Foot Augers - Models 300 & 302

PART #	DESCRIPTION	FLIGHTS USED		KICKER	BRACE	KICKER	BRACE
		R.H.	L.H.	10552	10721	16450	12454
A10731	Lower Left Hand w/ 3/8 fltg.	1-10726	6-10725	4	4	-	-
A10732	Lower Right Hand w/ 3/8 fltg.	1-10726	6-10725	-	4	-	-
A10730	Upper L.H. or R.H. w/ 1/4 fltg.	5-10727	1-10800	4	4	-	-
A12781	Upper L.H. Reverse w/ 1/4 fltg.	1-10727	5-10800	4	4	-	-
A10829	Lower Left Hand w/ 1/2 fltg.	1-10804	6-13557	4	4	-	-
A10830	Lower Right Hand w/ 1/2 fltg.	1-10804	6-13557	-	4	-	-
A10828	Upper L.H. or R.H. w/ 3/8 fltg.	5-10726	1-10725	4	4	-	-
A12782	Upper L.H. Reverse w/ 3/8 fltg.	1-10726	5-10725	4	4	-	-
A10728	Flanged Auger Tube 11' 8" x 4" od.						
10608	Auger Tube 11' 8" x 4" od.						
10640	Auger Flange (2 per auger)						

14 Foot Augers - Models 350 & 354

A10734	Lower Left Hand w/ 3/8 fltg.	1-10726	7-10725	4	4	-	-
A10735	Lower Right Hand w/ 3/8 fltg.	1-10726	8-10725	-	4	-	-
A10733	Upper L.H. or R.H. w/ 1/4 fltg.	6-10727	1-10800	4	4	-	-
A12785	Upper L.H. Reverse w/ 1/4 fltg.	1-10727	6-10800	4	2	-	-
A10826	Lower Left Hand w/ 1/2 fltg.	1-10804	7-13557	4	4	-	-
A10827	Lower Right Hand w/ 1/2 fltg.	1-10804	8-13557	-	4	-	-
A10825	Upper L.H. or R.H. w/ 3/8 fltg.	6-10726	1-10725	4	4	-	-
A12786	Upper L.H. Reverse w/ 3/8 fltg.	1-10726	6-10725	4	4	-	-
A12789	Lower L.H. w/ 1/2" fltg. & 5" tube MS	1-10806	6-13559	-	-	4	6
A12791	Lower R.H. w/ 1/2" fltg. & 5" tube MS	1-10806	8-13559	-	-	4	-
A10729	Flanged Auger Tube 13'8" x 4" od.						
10607	Auger Tube 13'8" x 4" od.						
10640	Auger Flange 4" ctr. (2 per auger)						
A12800	Flanged Auger Tube 13'8" x 5" od.						
12284	Auger Tube 13'8" x 5" od.						
10197	Auger Flange 5" ctr. (2 per auger)						

16 Foot Augers - Models 400 & 406

A10948	Lower Left Hand w/ 1/2 fltg.	1-10806	8-13559	4	-	4	-
A10949	Lower Right Hand w/ 1/2 fltg.	1-10806	9-13559	-	-	4	-
A10939	Upper L.H. or R.H. w/ 3/8 fltg.	7-10726	1-10725	4	4	-	-
A12792	Upper L.H. Reverse w/ 3/8 fltg.	1-10726	7-10725	4	4	-	-
A11558	Flanged Auger Tube 15'8" x 4" od.						
10509	Auger Tube 15'8" x 4" od.						
10640	Auger Flange 4" ctr. (2 per auger)						
A11559	Flanged Auger Tube 15'8" x 5" od.						
10508	Auger Tube 15'8" x 5" od.						
10197	Auger Flange 5" ctr. (2 per auger)						

18 Foot Augers - Model 458

A13588	Lower Left Hand w/ 1/2 fltg.	1-10806	9-13559	-	-	4	6
A13589	Lower Right Hand w/ 1/2 fltg.	1-10806	10-13559	-	-	4	-
A13584	Upper Left Hand w/ 1/2 fltg.	9-10806	10-13559	-	-	4	4
A13586	Upper Left Hand w/ 1/2" fltg.	9-10806	10-13559	4	6	4	4
A13585	Flanged Auger Tube Assy.						
10197	Flange 3/4" x 8" x 5" ID						
13597	Auger Tube 5" OD x 17' 8"						

Auger Nuts & Bolts

100321	Bolt 5/8 x 2 1/2 - 18 Gr. 5
100273	Lock washer 5/8
100248	Nut 5/8 18 Gr. 5

Auger Bearings Nuts & Bolts

100209	Bolt 5/8 x 2 1/2 - 17 Gr.
101952	Lock washer 5/8
100378	Nut 5/8 - 18 Gr. 5

BOTTOM LINERS	
10195	24" x 144" x 1/4
10194	24" x 24" x 1/4

FULL BOTTOMS	
10982	36" x 96" x 3/8
10981	36" x 72" x 3/8

DISCHARGE LINERS	
16065	Dual auger round bottom (2 per)
9489	R.H. dual auger
9490	L.H. dual auger
10742	S.A.D. 1/4" for round spout
10917	S.A.D. 10ga for flat spout
11849	S.A.D. 1/4" for flat spout

FLIGHTING	
10725	L.H. 3/8" x 20" - 4" I.D.
10726	R.H. 3/8" x 20" - 4" I.D.
10727	R.H. 1/4" x 20" - 4" I.D.
10800	L.H. 1/4" x 20" - 4" I.D.
10801	R.H. 3/16" x 20" - 4" I.D. (S.A.D.)
10809	R.H. 3/16" x 20" - 4" Ellipsed (S.A.D.)
10804	R.H. 1/2" x 20" - 4" I.D.
13557	L.H. 1/2" x 20" - 4" I.D.
10806	R.H. 1/2" x 20" - 5" I.D.
13559	L.H. 1/2" x 20" - 5" I.D.
12460R	Dual discharge R.H. 3/16" x 12"
124606	Dual discharge flights L.H. 3/16" x 12"
10552	Angle Kicker 1/4 x 2 x 2 x 7 1/2 Lg.
10721	Brace 1 1/2 x 1/2 x 7 Lg.
12454	Angle kicker 1/2 x 3 x 3 x 7 1/2 Lg.

SIDES	
10743	48" X 144" X 10ga
10744	48" x 168" x 10ga
10048	48" x 192" x 10ga

END PANELS	
16168	Plate, wear lower end (2 needed)
16475	Liner, end (Top)
16476	Liner, end (Middle)

FENDERS	
10563	60" Finder
10564	72" Finder

AUGER NUTS & BOLTS	
100321	Bolt 5/8 X 2 1/2 -18 Gr. 5
100273	Lock washer 5/8
100248	Nut 5/8 18 Gr. 5

AUGER BEARING NUTS & BOLTS	
100209	Bolt 5/8 x 2 1/2 - 17 Gr. 5
101952	Lock washer 5/8
100378	Nut 5/8 - 18 Gr. 5

DECALS FOR MIXERS

101181	Door gauge
100992	Scale
100923	Load cell warning
102070	Oil Bath Maintenance
102069	Maintenance (Overall)
102109	Caution, Before Welding
101178	Model 300
101179	Model 350
101180	Model 400
302	Model 302
354	Model 354
406	Model 406
101173	F
101174	R
101175	T
101176	M
101177	ST
100487	Rear (large triangle) <i>replaced by 100488</i>
100488	Side
CAUTION	Caution Kit includes the following
*	102339 Danger Rotating Augers
*	102107 Danger D/L 540 rpm.
*	102108 Danger D/L 1000rpm.
*	102358 Danger D/L Trailer
*	102071 Danger Do Not Enter
*	102370 Danger Do Not Operate W/out Shield

*** Caution Kit will be included with any other decal purchase**

DISCHARGE CABLE KIT

H U 0A7484

Step To Disassemble See Figure 1

1. Remove cylinder and existing mount.
2. Disconnect the hydraulic lines from the "T" fittings, plug fitting ends with the provided plugs in your discharge cable kit.

Steps To Assemble See Figure 2

1. Install new mounting bracket.
2. Attach the cable adjustment bracket to the bottom of the discharge hinge tube of the cylinder bracket.
3. Attach cable to the clutch lever arm of the gear box with one of the furnished cable clamps.
4. Run cable through the pulley on the new mounting bracket, attach (with the furnished clamp) to the adjustment bracket on discharge.

To Adjust Cable

1. Have drop spout in up position.
2. Adjust cable so clutch is fully disengaged. To obtain adequate cable tension, the cable adjustment bracket must be turned in a counter-clock wise direction.

Note: The JIC-6 Hydraulic Female Plugs fit the original hydraulic fittings. Plug size may vary if work has been done to the unit.

Figure 1

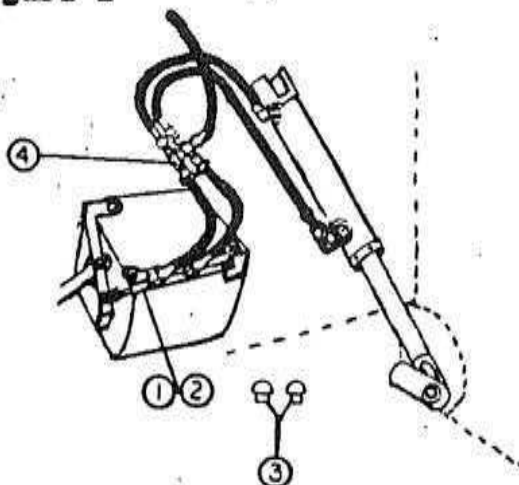

ITEM NO	PART NO	DESCRIPTION
1	N/A	CYLINDER
2	N/A	BRACKET
3	N/A	JIC-6 HYDRAULIC FEMALE PLUGS
4	N/A	TEE

Figure 2

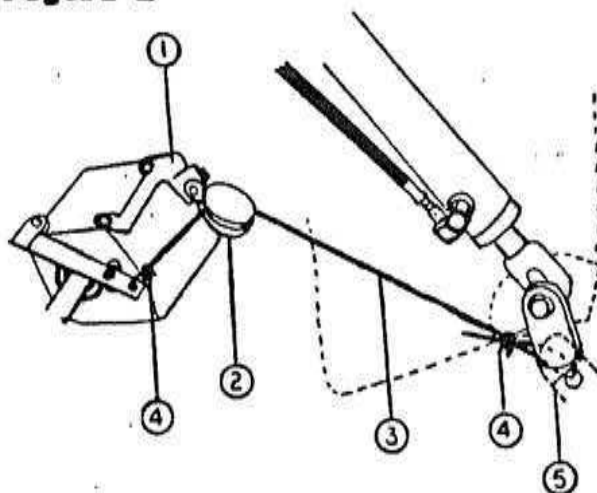

ITEM NO	PART NO	DESCRIPTION	QTY REQD
1	A16354	BRACKET	1
2	100307	PULLEY	1
3	7070227	3/16" CABLE	1
4	100306	CABLE CLAMP	2
5	A16355	CABLE ADJUSTMENT BRACKET	1

REV LET	DESCRIPTION OF CHANGE	ECC NO
N/C	NEW RELEASE:	90-10-24

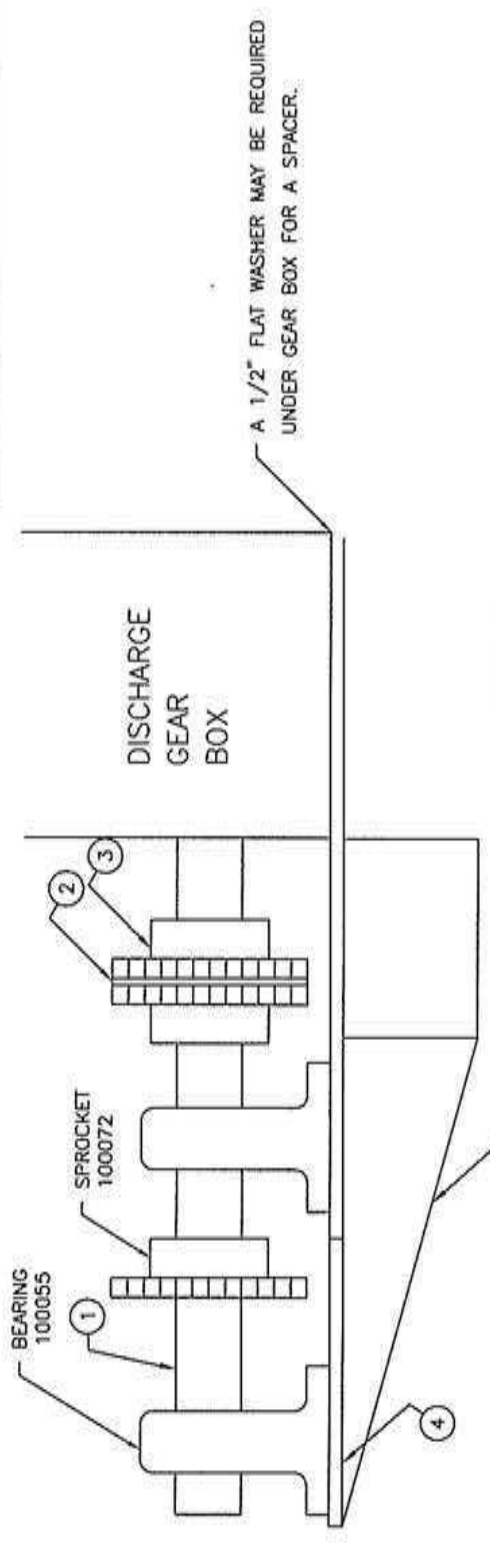

QTY	ITEM	PART NO	DESCRIPTION
1	1	16875	SHAFT, DRIVE 1 1/4 O.D.x10 LG
1	2	102443	CHAIN, COUPLING
2	3	102442	SPROCKET, CHAIN COUPLING 1 1/4 I.D.
1	4	16877	PLATE, BEARING MOUNT
1	5	16876	GUSSET, 1/4x3x7.75
MATERIAL	UNIT	MATL NO	MATERIAL DESCRIPTION

CUSTOMER: _____

TITLE: HD DRIVE, DURST DUEL AUGER DIS.

REV: N/C

DRAWING NO: A9488

REV SHEET 1 of 1

DATE: 11/1/90

SCALE: 1/2

DESIGNED BY: _____

CHECKED BY: _____

DATE: _____

APPROVED BY: _____

DATE: _____

RELEASE ECC: 90-10-24

FINAL ASSY

UNLESS OTHERWISE SPECIFIED ALL DIMENSIONS IN DIMITHS ARE REQUIRED SURFACES TO BE FINISHED BY _____

BRANDS: HARSH INTERNATIONAL

10000000

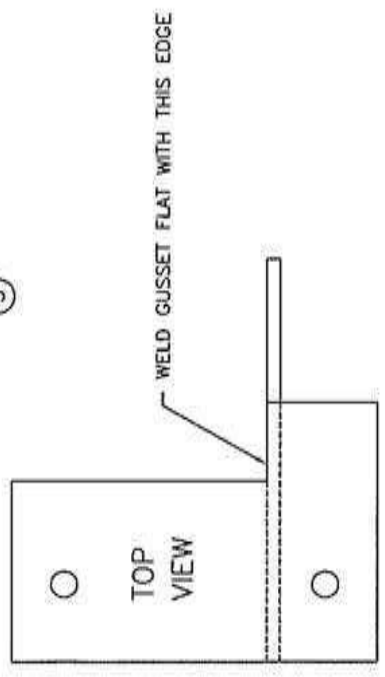

CAD DRAWING--DO NOT REVISE MANUALLY
 REPORT ERRORS TO ENGINEERING DEPARTMENT

HARGH

MOBILE MIX

GEAR BOX SYSTEMS

COMPLETE BREAKDOWN

SINGLE AUGER DISCHARGE GEAR BOX

Always give Model Number and Serial Number when ordering parts.

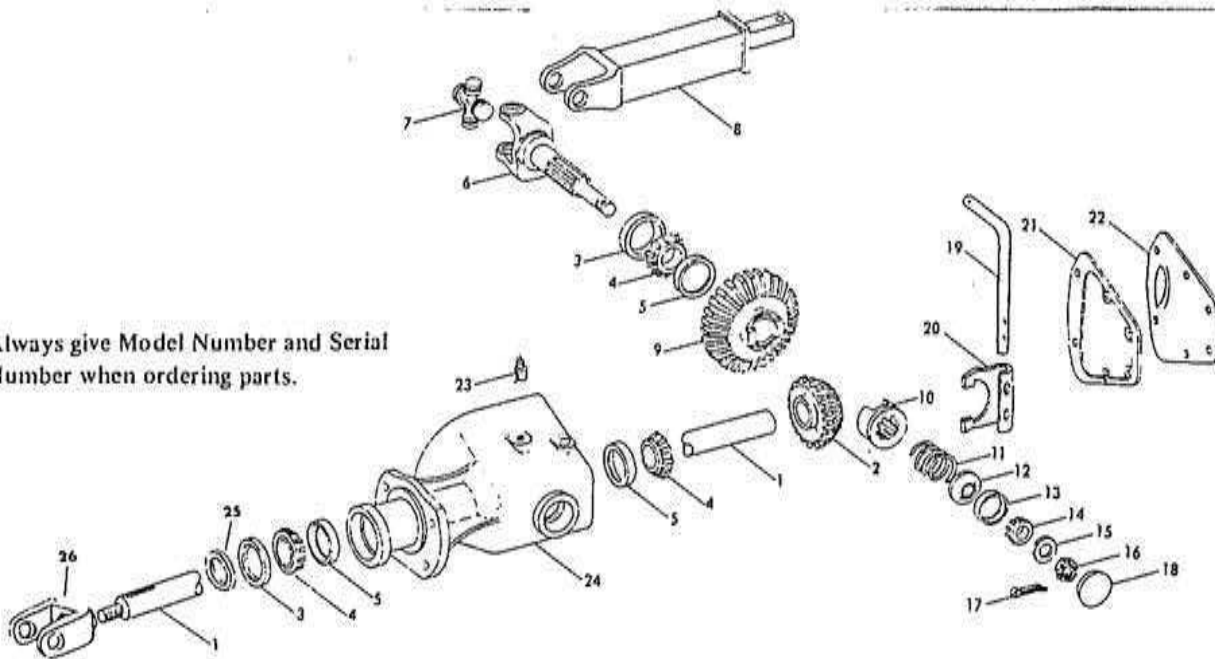

ITEM NO.	H.U. NO.	DESCRIPTION	NO. REQ'D
	100305	Gear box complete	1
1	4102	Shaft and pinion assembly	1
3	4103	Oil seal	2
4	4104	Tapered roller bearing cone	3
5	4105	Tapered roller bearing cup	3
6	4106	Yoke and shaft weld assembly	1
7	4107	Cross kit 1275X	1
8	4108	Telescoping shaft weld assembly	1
9	4109	Bevel gear	1
10	4110	Clutch collar	1
11	4111	Clutch spring	1
12	4112	Spring stop	1
13	4113	Tapered roller bearing cone	1
14	4114	Tapered roller bearing cup	1
15		Plain washer 3/4"	1
16		Special hex nut	1
17		Cotter pin 1/8" x 1 1/4"	1
18	4115	Cap	1
19	4116	Clutch release shaft	1
20	4117	Clutch yoke	1
21	4118	Gasket	1
22	4215	Cover	1
23		Fill plug assembly	1
24	4175	Gear box housing	1
25	10920	Output shaft collar	
26	10626	Special H-10 yoke	

**DUAL AUGER DISCHARGE GEAR BOX
LOCATED UNDERNEATH MIXER ON PASSENGER SIDE**

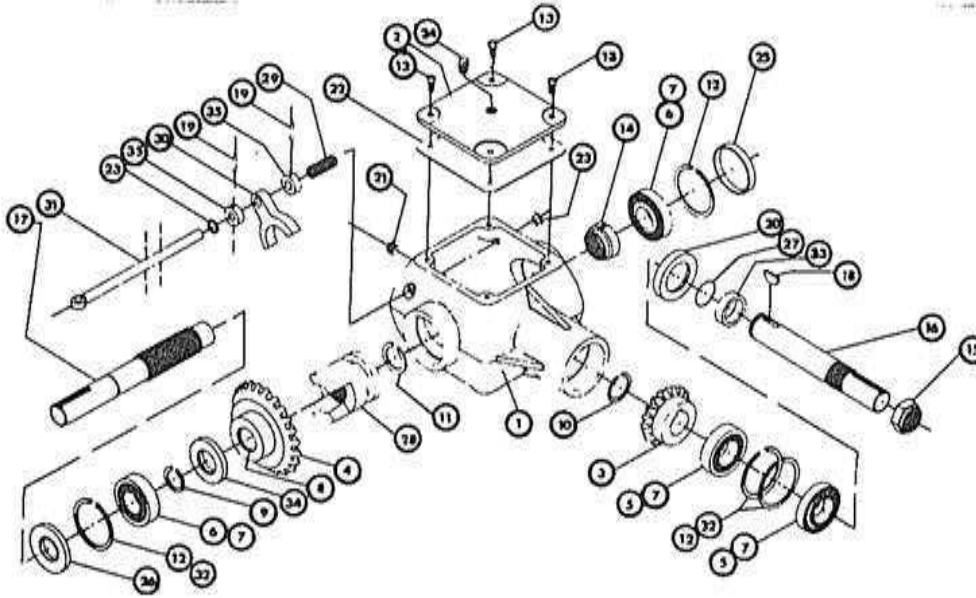

ITEM NO.	H.U. NO.	DESCRIPTION	NO. REQ'D
	101063	Complete gear box	1
1	102210	Housing	1
2	102211	Cover	1
3	4278	Pinion gear	1
4	4279	Gear bevel	2
5	102213	Bearing Cone	2
6	4094	Bearing cone	4
7	4093	Bearing cone	1
8	102212	Bushing	1
9	4280	Snap ring	1
10	4281	Snap ring	1
11	102214	Snap ring	3
12	4282	Snap ring	4
13	4283	Cap screw	1
14	4286	Stake nut	1
15	4284	Stake nut	1
16	4288	Output shaft	1
17	4287	Input shaft	1
18	102215	Woodruff key	2
19	102218	Roll pin	1
20	4289	Seal	1
21		Plug	1
22	4290	Gasket	2
23	4291	Seal	1
24	102217	Plug vent	1
25	102216	Cap	1
26	4292	Seal	1
27	4293	O-ring	1
28	4294	Clutch	1
29	4297	Spring	1
30	4295	Yoke	1
31	4296	Shift rod assembly	1
32	4285	Shim	2
33	4299	Spacer output	1
34	4300	Spacer input	1
35	4301	Coller	2

**DUAL AUGER DISCHARGE GEAR BOX
LOCATED IN FRONT OF DISCHARGE**

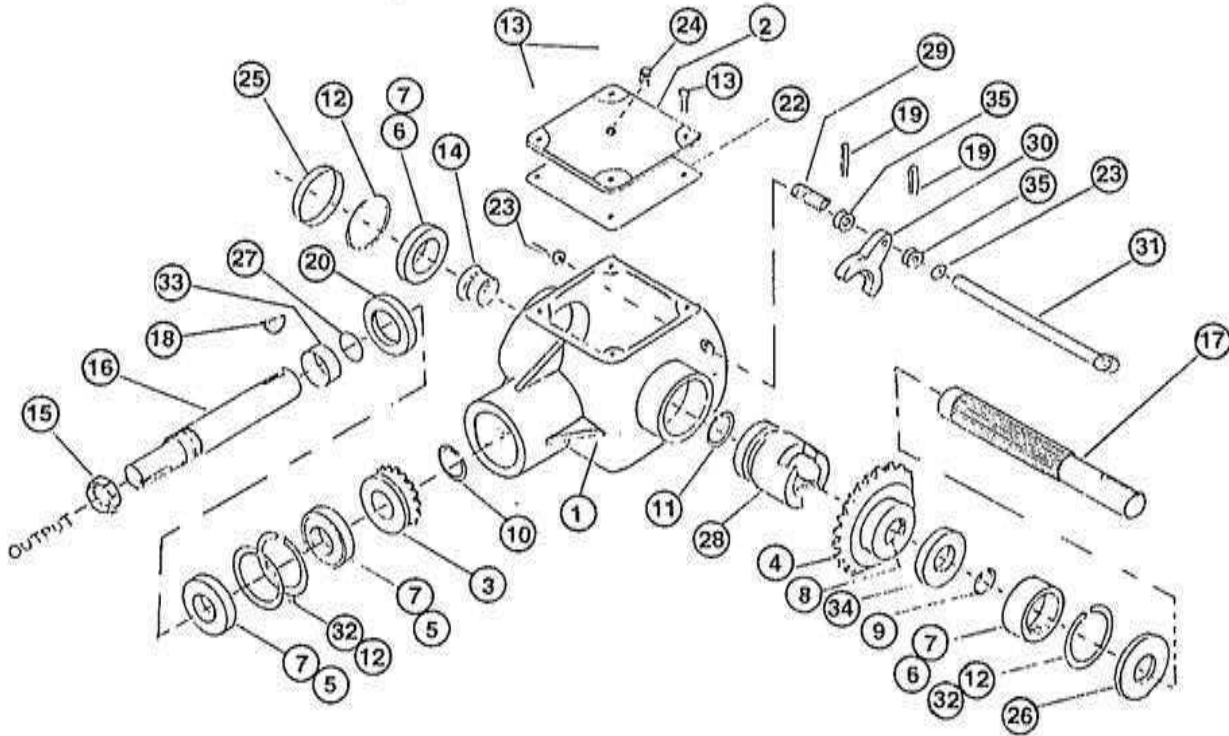

ITEM NO.	H.U. NO.	DESCRIPTION	NO. REQ'D
	101684	Complete gear box	1
1	102210	Housing	1
2	102211	Cover	1
3	4278	Pinion gear	1
4	4279	Gear bevel	2
5	102213	Bearing cone	2
6	4094	Bearing cone	4
7	4093	Bearing cone	1
8	102212	Bushing	1
9	4280	Snap ring	1
10	4281	Snap ring	1
11	102214	Snap ring	3
12	4282	Snap ring	4
13	4283	Cap screw	1
14	4286	Stake nut	1
15	4284	Stake nut	1
16	4288	Output shaft	1
17	4287	Input shaft	1
18	102215	Woodruff key	2
19	102218	Roll pin	1
20	4289	Seal	1
21		Plug	1
22	4290	Gasket	2
23	4291	Seal	1
24	102217	Plug vent	1
25	102216	Cap	1
26	4292	Seal	1
27	4293	O-ring	1
28	4294	Clutch	1
29	4297	Spring	1
30	4295	Yoke	1
31	4296	Shift rod assembly	1
32	4285	Shim	2
33	4299	Spacer output	1
34	4300	Spacer input	1
35	4301	Coller	2

AKON

Hydraulics
Limited Mfg. Co.

1020 DAK STREET • EATON, COLORADO 80615
 (303) 454-3281

DUAL AUGER DISCHARGE WITH TWO GEAR BOXES PART #302088C

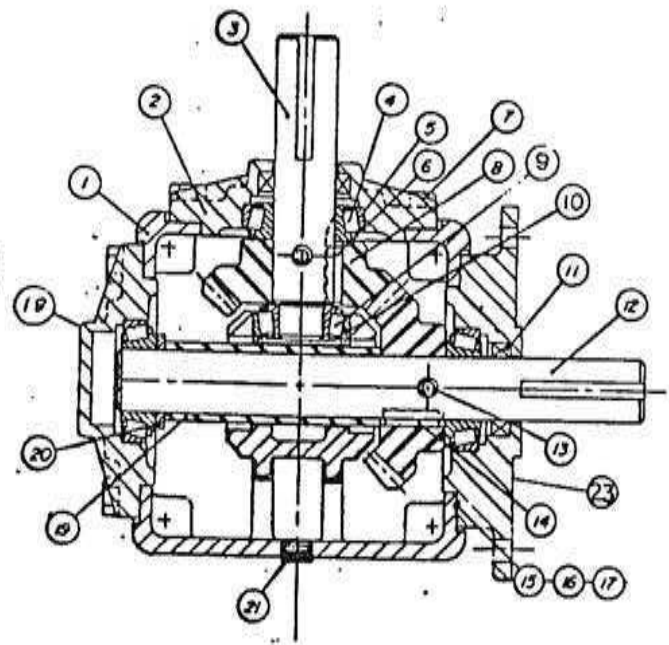

(22) (24) (25) (26) NOT ILLUSTRATED

QTY	ITEM NO.	PART NO.	DESCRIPTION
1	1	102204	HOUSING
1	2	102201	CAP
1	3	102182	SHAFT
3	4	102183	BEARING CONE
3	5	102184	BEARING CUP
1	6	102190	KEYS
8	7	102203	SEMS SCREWS
2	8	102187	GEAR
1	9	102185	BEARING CONE
1	10	102186	BEARING CUP
2	11	102188	SEAL
1	12	102198	SHAFT
2	13	102189	ROLL PIN
1	14	102191	KEY
VAR	15	102195	GASKET (.015)
VAR	16	102193	GASKET (.005)
VAR	17	102192	GASKET (.003)
1	18	102181	BLANK CAP
1	19	102200	SPACER
1	20	102199	WASHER
2	21	-	PIPE PLUG (PLAIN)
1	22	102196	PIPE PLUG (VENTED)
1	23	102197	FLANGE CAP
4	24	102202	SOCKET HEAD CAP SCREW
1	25	-	I.D. TAG
4	26	-	PIVET

JARSH.

Hydraulics
 Unlimited Mfg. Co.

800 OAK STREET • EATON, COLORADO 80615
 (303) 454-2291

DUAL AUGER DISCHARGE WITH TWO GEAR BOXES PART #302111C

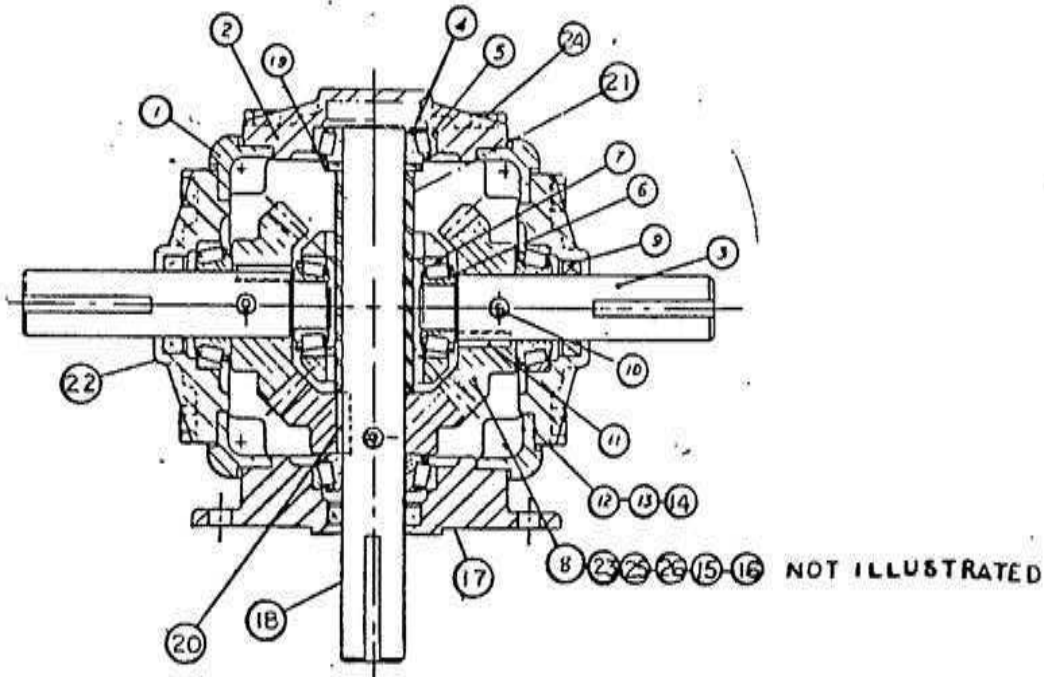

QTY	ITEM NO.	PART NO.	DESCRIPTION
1	1	102180	HOUSING
1	2	102181	BLANK CAP
2	3	102182	SHAFT
4	4	102183	BEARING CONE
4	5	102184	BEARING CUP
2	6	102185	BEARING CONE
2	7	102186	BEARING CUP
3	8	102187	GEAR
3	9	102188	SEAL
3	10	102189	ROLL PIN
2	11	102190	KEY
VAR	12	102195	GASKET (.015)
VAR	13	102193	GASKET (.010)
VAR	14	102192	GASKET (.005)
1	15	-	PIPE PLUG (PLAIN)
1	16	102196	PIPE PLUG (VENTED)
1	17	102197	FLANGE CAP
1	18	102198	SHAFT
1	19	102199	WASHER
1	20	102191	KEY
1	21	102200	SPACER
2	22	102201	CAP
4	23	102202	SOCKET HEAD SCREW
12	24	102203	SEMS SCREWS
1	25	-	I. D. TAG

**MODEL
BJ-48A & BJ-48
GEAR BOX**

ITEM	PART #	DESCRIPTION	QTY.
1	100441	BJ 48A GEAR BOX (3 SHAFTS VISIBLE)	
2	4151	HOUSING	
3		SIDE COVER PLATE	
4	4143	LOW SPEED OPEN CAP	2
5	4090	HIGH SPEED OPEN CAP	1
6	4089	HIGH SPEED CLOSED CAP	1
7	4153	LOW SPEED SHAFT	1
8	4152	HIGH SPEED PINION	1
9	4092	LOW SPEED GEAR	1
10			
11			
12			
13	4093	BEARING CUP HIGH SPEED	2
14	4094	BEARING CONE HIGH SPEED	2
15	4095	BEARING CUP LOW SPEED	2
16	4096	BEARING CONE LOW SPEED	2
17			
18	4098	SHIM SHAFT SET	2 lots
19		CAP SCREW	24
20		CAP SCREW	20
21	4099	CORK GASKET	2
22		PIPE PLUG	3
23		BREATHER PLUG	1
24		MAGNETIC DRAIN PLUG	1
25	4204	TURNBUCKLE ROD R.H.	1
26		STUD	1
27	4144	SPACER	1
28		JAM NUT R.H.	2
29	4100	LOW SPEED OIL SEAL	2
30	4101	HIGH SPEED OIL SEAL	2
31			
32			
33	4202	BEARING SPACER RING	
34	4203	BEARING SPACER RING	
35		BJ-48	
36	100299	BJ-48 GEAR BOX (4 SHAFTS VISIBLE)	1
37	4091	HIGH SPEED PINION (100299 ONLY)	1

HARSH



MODEL 8324 PARTS LIST

PLANETARY REPLACEMENT KIT
A9581

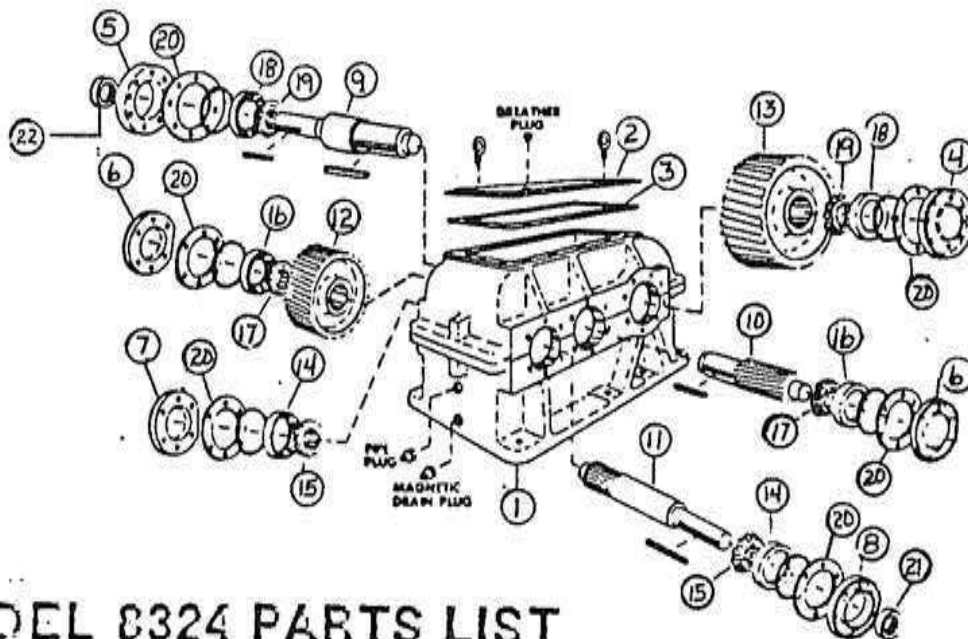

MODEL 8324 PARTS LIST

ITEM NO	H. U. NUMBER	DESCRIPTION	NO REQD
	100298	R.H. Gear Box	
1		Case (Special Order)	1
2		Cover Plate	1
3	4067	Cover Plate Gasket	1
4	4068	L.S. Closed Cap	1
5	4069	L.S. Open Cap	1
6	4070	Intermediate Cap	2
7	4071	H.S. Closed Cap	1
8	4072	H.S. Open	1
9	4073	L.S. Shaft	1
10	4074	Intermediate Pinion Shaft	1
11	4075	H.S. Pinion Shaft	1
12	4076	Intermediate Gear	1
13	4077	L.S. Gear	1
14	4078	H.S. Bearing Cup	2
15	4079	H.S. Bearing Cone	2
16	4080	Intermediate Bearing Cup	2
17	4081	Intermediate Bearing Cone	2
18	4082	L.S. Bearing Cup	2
19	4083	L.S. Bearing Cone	2
20	4084	Shim Set (All Caps)	1
21	4085+4436	H.S. Oil Seal +CAP-DRAIN STYLE	1
22	4086	L.S. Oil Seal	

All prices are F.O.B. Eaton, Colorado and subject to change without notice.

HARSH

Hydraulics
 Unlimited Mfg. Co.
 800 OAK STREET • EATON, COLORADO 80615 • (303) 454-2291
MOBILE MIX

MODEL 8309 PARTS LIST

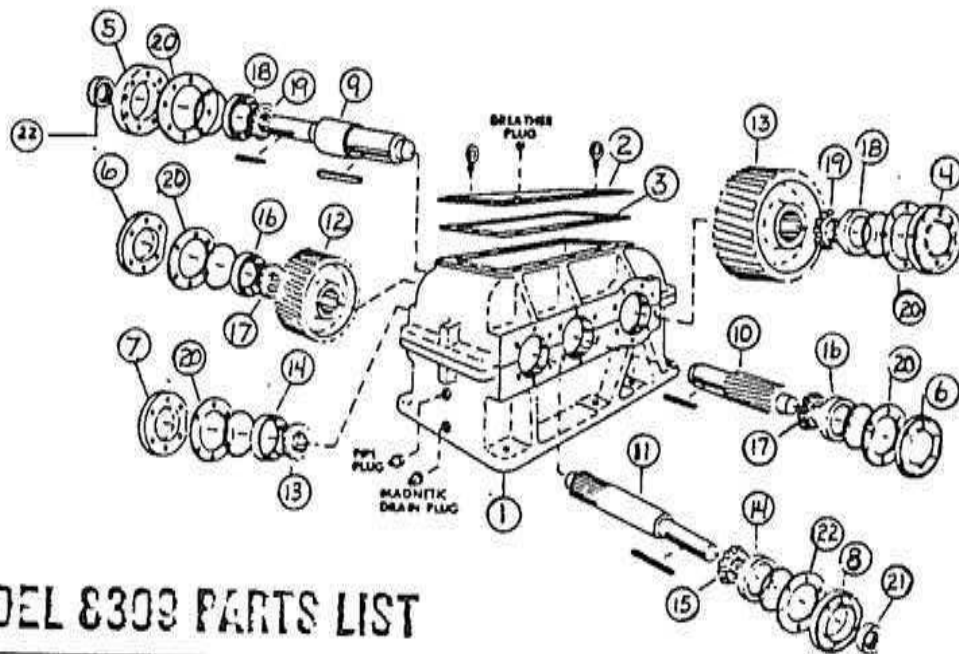

MODEL 8309 PARTS LIST

ITEM NO	H. U. NUMBER	DESCRIPTION	NO REQD
	100807	R.H. Gear Box (9 to 1) Case (Special Order)	
1		Case (Special Order)	1
2		Cover Plate	1
3	4067	Cover Plate Gasket	1
4	4068	Low Speed Closed Cap	1
5	4069	Low Speed Open Cap	1
6	4070	Intermediate Cap	2
7	4071	High Speed Closed Cap	1
8	4072	High Speed Open Cap	1
9	4073	Low Speed Shaft	1
10	4234	Intermediate Pinion Shaft	1
11	4235	High Speed Pinion Shaft	1
12	4236	Intermediate Gear	1
13	4237	Low Speed Gear	1
14	4227	High Speed Bearing Cup	2
15	4228	High Speed Bearing Cone	2
16	4080	Intermediate Bearing Cup	2
17	4081	Intermediate Bearing Cone	2
18	4082	Low Speed Bearing Cup	2
19	4083	Low Speed Bearing Cone	2
20	4084	Shim Set (All Caps)	1
21	4232	High Speed Oil Seal	1
22	4086	Low Speed Oil Seal	1

All prices are F.O.B. Eaton, Colorado and subject to change without notice.

HARSH®

Hydraulics
Unlimited Mfg. Co.
 800 OAK STREET • EATON, COLORADO 80615 • (303) 454-2201
MOBILE MIX®

MODEL 58055RH SERIES SPEED REDUCERS

USED ON M AND MS SERIES

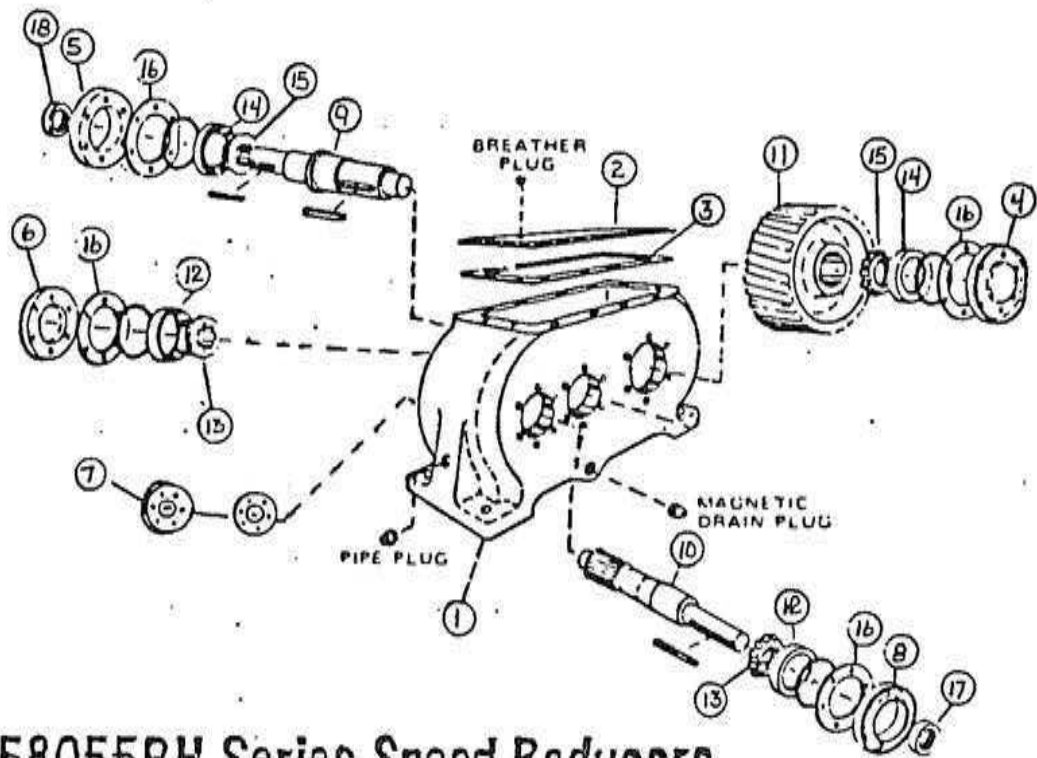

Model 58055RH Series Speed Reducers

ITEM NO	H. U. NUMBER	DESCRIPTION	NO REQD
	100971	58055 Complete (5.5 to 1)	
1	4216	Case (Special Order)	1
2	4217	Cover Plate	1
3	4067	Cover Plate Gasket	1
4	4068	Low Speed Closed Cap	1
5	4069	Low Speed Open Cap	1
6	4070	Intermediate Closed Cap	2
7	4071	High Speed Closed Cap	1
8	4072	High Speed Open Cap	1
9	4224	Low Speed Shaft (2 3/4")	1
10	4225	High Speed Pinion Shaft (1 3/8")	1
11	4226	Low Speed Gear	1
12	4227	High Speed Bearing Cup	2
13	4228	High Speed Bearing Cone	2
14	4229	Low Speed Bearing Cup	2
15	4230	Low Speed Bearing Cone	2
16	4084	Shim Set (All Caps)	1
17	4232	High Speed Oil Seal	1
18	4066	Low Speed Oil Seal	1



MODEL 5809RK SERIES SPEED REDUCERS

USED ON M AND MS SERIES

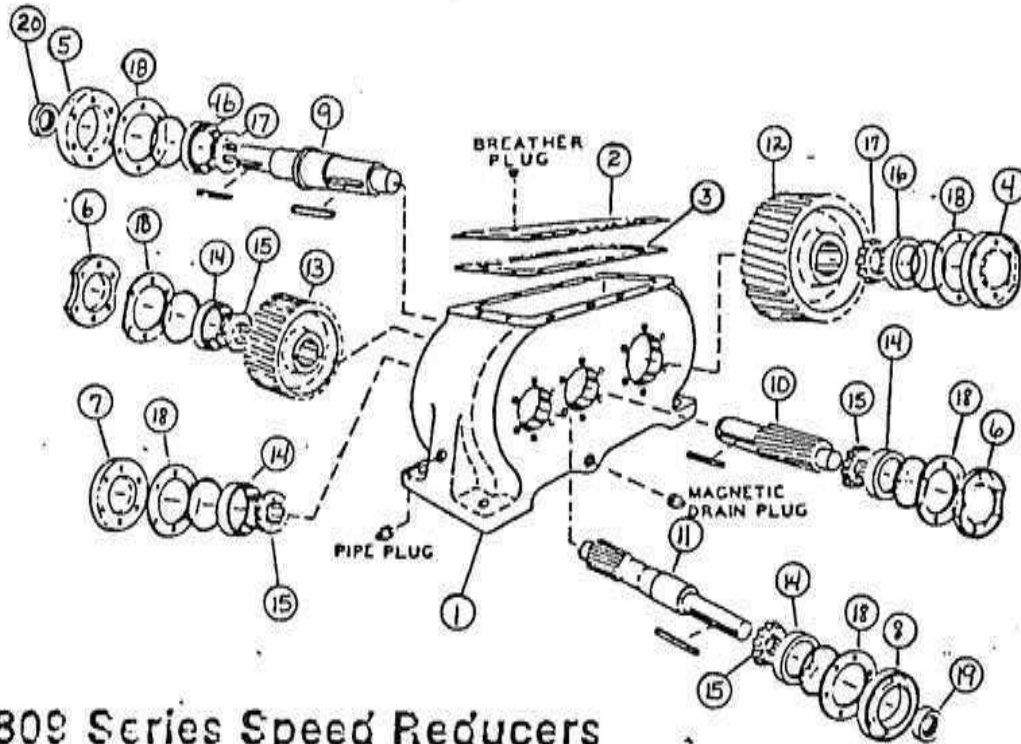

Model 5809 Series Speed Reducers

ITEM NO	H. U. NUMBER	DESCRIPTION	NO REQD
	101401	5809 Complete (9 to 1)	
1	4216	Case (Special Order)	1
2	4217	Cover Plate	1
3	4067	Cover Plate Gasket	1
4	4068	Low Speed Closed Cap	1
5	4069	Low Speed Open Cap	1
6	4070	Intermediate Closed Cap	2
7	4071	High Speed Closed Cap	1
8	4072	High Speed Open Cap	1
9	4224	Low Speed Shaft (2 3/4")	1
10	4322	Intermediate Pinion Shaft	
11	4323	High Speed Pinion Shaft (1 3/8")	1
12	4325	Low Speed Gear	1
13	4324	Intermediate Pinion Gear	
14	4227	High Speed Bearing Cup	2
15	4228	High Speed Bearing Cone	2
16	4229	Low Speed Bearing Cup	2
17	4230	Low Speed Bearing Conc	2
18	4084	Shim Set (All Caps)	1
19	4232	High Speed Oil Seal	1
20	4086	Low Speed Oil Seal	1

All prices are F.O.B. Eaton, Colorado and subject to change without notice.

HARSH

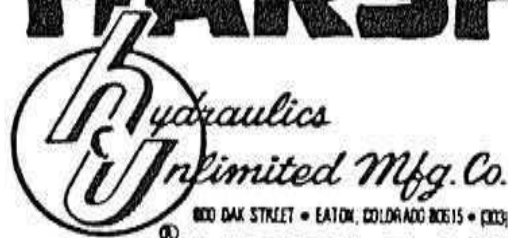

800 DAK STREET • EATON, COLORADO 80515 • (303) 454-2291

MOBILE MIX

MODEL 8340X PARTS LIST

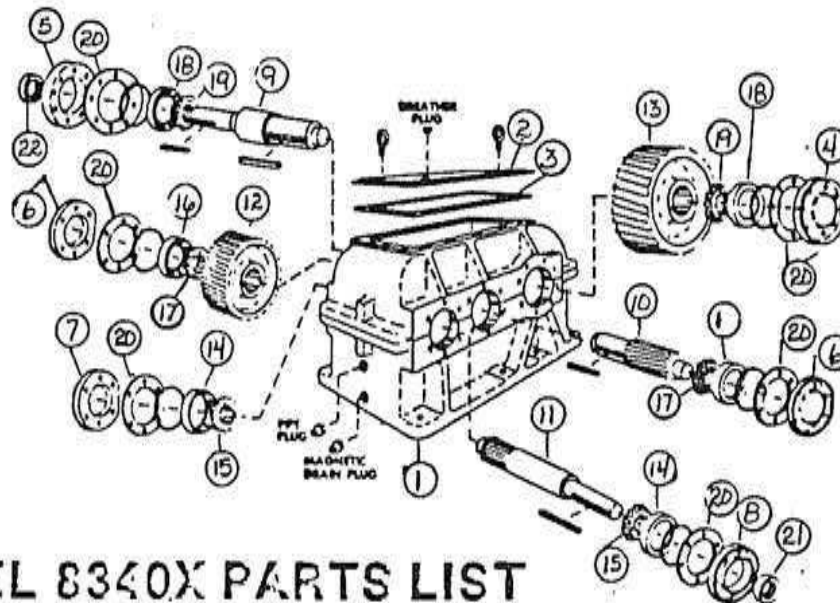

MODEL 8340X PARTS LIST

ITEM NO	H. U. NUMBER	DESCRIPTION	NO REQD
	100425	Gear Box Complete L.H.	1
1		Case Assembly (Sold only as an assembly)	1
2		Cover Plate	1
3	4067	Cover Plate Gasket	1
4	4068	Low Speed Closed Cap	1
5	4069	Low Speed Open Cap	1
6	4070	Intermediate Cap	2
7	4071	High Speed Closed Cap	1
8	4072	High Speed Open Cap	1
9	4073	Low Speed Shaft	1
10	4237	Intermediate Pinion Shaft	1
11	4087	High Speed Pinion Shaft	1
12	4138	Intermediate Gear	1
13	4139	Low Speed Gear	1
14	4078	Timken Bearing Cup H.S.	2
15	4136	Timken Bearing Cone H.S.	2
16	4080	Timken Bearing Cup Int.	2
17	4081	Timken Bearing Cone Int.	2
18	4082	Timken Bearing Cup L.S.	2
19	4083	Timken Bearing Cone L.S.	2
20	4084	Shim Set (All Caps)	1
21	4088	High Speed Oil Seal	1
22	4086	Low Speed Oil Seal	1

All prices are F.O.B. Eaton, Colorado and subject to change without notice.

NOTE:



1 NOT TO SCALE
2 MAINTAIN ALL SPROCKET ALIGNMENTS

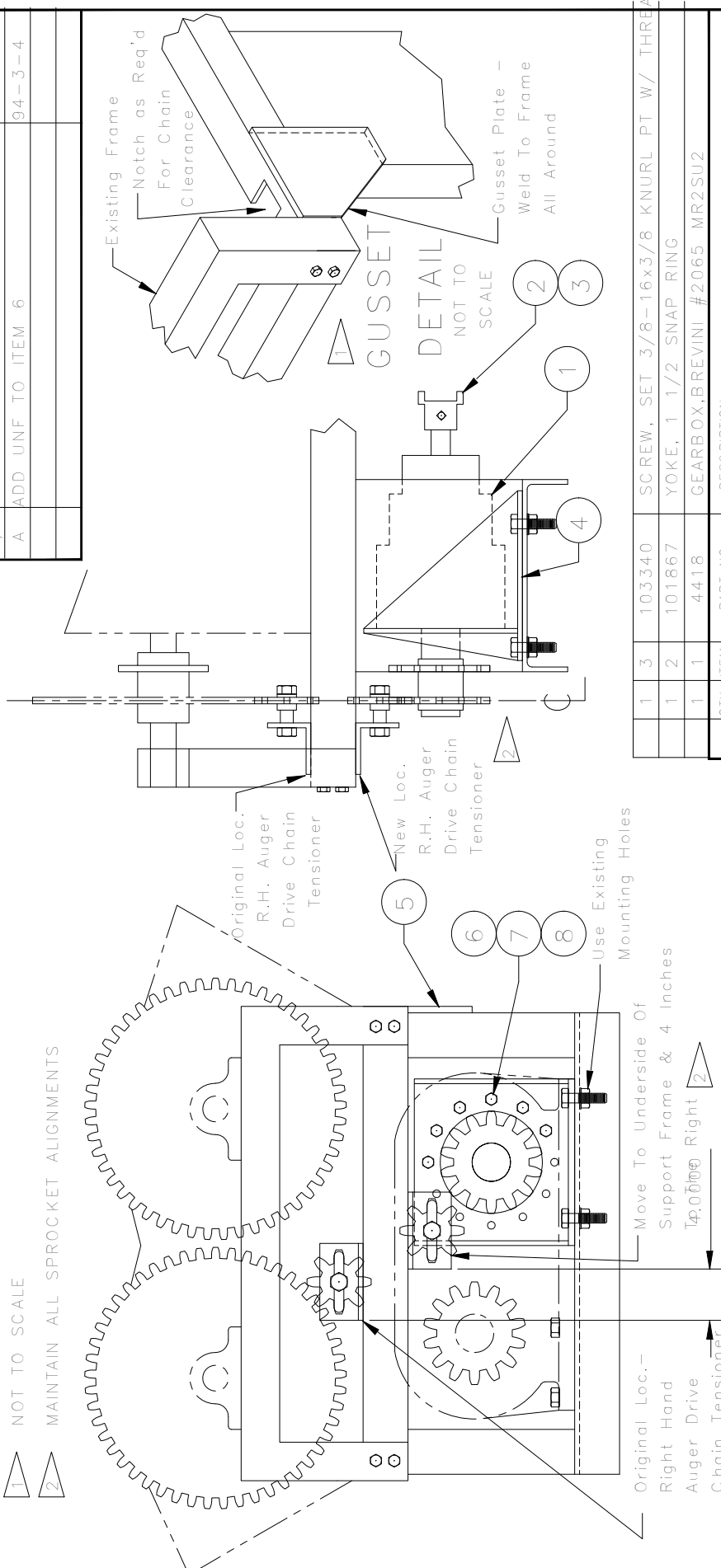

REV LET	DESCRIPTION OF CHANGE	ECO NO
N/C	NEW RELEASE	92-2-5
A	ADD UNF TO ITEM 6	94-3-4

1	3	103340	SCREW, SET 3/8-16x3/8 KNURL PT W/ THREAD
1	2	101867	YOKE, 1 1/2 SNAP RING
1	1	4418	GEARBOX,BREVINI #2065 MR2SU2
QTY	ITEM	PART NO	DESCRIPTION
MATL SIZE	UNIT	MATL NO	MATERIAL DESCRIPTION
CUSTOMER MM			
TITLE			
KIT, CONVERSION			
DOR, 8324 - BREVINI			
SIZE	DRAWING NO	REV	REV
B	A9581	A	A
TEMP NO 9500/9581		SHEET 1 of 1	
DRAWN BY: JMB		DATE: 2/14/92	
CHECKED BY:		APPROVED BY:	
DATE:		DATE:	

RELEASE ECO# 92-2-5	
FINAL ASSY MM	
KIT, CONVERSION	
DOR, 8324 - BREVINI	
SIZE	DRAWING NO
B	A9581
TEMP NO 9500/9581	REV
	A
SHEET 1 of 1	
DATE: 2/14/92	
DRAWN BY: JMB	
CHECKED BY:	
APPROVED BY:	
DATE:	

QTY	ITEM	PART NO	DESCRIPTION
1	A9581		PARTS LIST & ASSEMBLY DRAWING
1	100315		LINK, OFFSET #100
1	100316		LINK, CONNECTING #100
15"	7070507		CHAIN #100 RIVETED - 12 PITCHES
12	8	100250	NUT, HEX 1/2-20 UNF GR5
12	7	100272	WASHER, LOCK 1/2
12	6	100230	SCREW, HX HD CAP 1/2-20UNF x 2
1	5	9594	PLATE, GUSSET
1	4	A9485	MOUNT, DORRIS - PLANETARY CONV.

100090 SPROCKET, H100 B19X3" *NOT INCLUDED*

CAD DRAWING - DO NOT REVISE MANUALLY
REPORT ERRORS TO ENGINEERING DEPARTMENT

Unless Otherwise Specified:
All Dimensions in Inches
All Machine Surfaces
12"
Break All Sharp Corners
.010-Max.
Tolerances:
Dec. XXX.03
XXX.XXX
Frac. 1/16"
Angles 1°
12"
12"

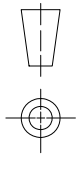

HARSH INTERNATIONAL
800 OAK AVE.
EATON, CO., R0F15

H01102521

2-24-90

A7451

17426

CURTIS TO DURST CONVERSION

307

ITEM NUMBER	DESCRIPTION		QTY
✓ 100037	GREASE FITTING, 1/4 DRIVE IN	34.28	2
✓ 100055	BEARING, 1 1/4 PILLOW BLOCK (BALL)	8.3	2
✓ 100072	SPROCKET, H60B13 x 1 1/4 100026	10.2	3
✓ 100240	SCREW, HX HD 3/8-16 x 1 1/4 GR5	34.59	8
✓ 100250	NUT, HX 1/2-20 UNF GR5	7-2 28.5	4
✓ 100254	NUT, HX 3/8-16 UNC GR5	34.31	8
✓ 100271	LOCK WASHER, 3/8	34.33	8
✓ 100272	LOCK WASHER, 1/2	28- 6	8
✓ 100281	SCREW, HX HD 1/2-13 x 1 UNC GR2	84.44	4
✓ 100356	SCREW HX HD CAP 5/16-18 x 2	34.41	8
✓ 100446	SPRING, 1 1/8 RD x 5 1/2	15.7	3
✓ 101314	SPROCKET, H86CA13 5/8 BEARING	10.3	1
✓ 101684	DURST GEAR BOX, A-15 W/SHIFT (USED)	17.1	1
✓ 101700	SPROCKET, DOUBLE-SINGLE 60 P/B	11.2	1
✓ 101830	COLLAR, SET SCREW 3/4 ID	12.2A	4
✓ ¹⁶⁸¹⁹ 101843	BEARING, INSERT 1 1/4 (CYLINDRICAL OD)	7.2	4
✓ 101875	CHAIN COUPLER, C40-16	11.2	1
✓ 101994	CHAIN COUPLER HALF 1 1/4	11.2	2
✓ 10549	DRIVE SHAFT 1 1/4 OD x 7 1/2 LG	7.3	1
✓ 10983	KEY, D3 5/16 x 1 1/2 LG	12.2C	6
12461	CHAIN, #60 x 48 3/4 LG 65 PITCH	26.1	2
✓ 15023	PIN, DISCHARGE IDLER 3/4 OD x 3 1/2 LG	34.60	2
✓ 15114	HOOK, SPRING 5/16 OD x 3	34.60	2
✓ 15517	CAP, DISCHARGE BEARING 3 3/4 x 1/2 DEEP	8.3	2
✓ 7070505	CHAIN, #60 RIVETED	19.2	5.50
✓ 7070505	CHAIN, #60 RIVETED	19.2	8.88
✓ 7070514	CHAIN, LOG 3/16 PLATED	7.1	1
✓ A14250	IDLER SPROCKET MOUNT ASS'Y	4.4	1
✓ A14418	BEAR BOX MOUNT ASS'Y	5.4	1
✓ A14422	MOUNT ASS'Y, BEARING 1/2 x 4 x 4 x 7 1/2	5.4	1

18

15

34

61

83

30

149

74

48

66 in dia

20

1

1

2

6

24

23

20

1

24

4

16

2

2

237

257

25

1-F-10

4

4

need 16819

need 3

need 1

need 2

